

Министерство образования Республики Беларусь  
Учреждение образования  
«Белорусский государственный университет  
информатики и радиоэлектроники»

Кафедра иностранных языков №1

Учебно-методическое пособие  
по развитию навыков чтения на английском языке  
для студентов 2-го курса ФКП, ФРЭ, ФТК, ВФ БГУИР  
дневной формы обучения

Reader for the second-year students

Минск 2007

УДК 811.111(075.8)  
ББК 81.2 Англ я 73  
У 91

Авторы-составители:

Т. В. Левкович, А. М. Лазаренко, И. И. Лихтарович, С. И. Лягушевич,  
И. Г. Маликова, А. К. Романюк, Г. Ф. Табакова, Н. В. Ушакова, Л. Е. Яцевич

У 91 Учебно-методическое пособие по развитию навыков чтения на английском языке для студентов 2-го курса ФКП, ФРЭ, ФТК, ВФ БГУИР дневн. формы обуч./ сост. Т.В. Левкович [и др.]. – Минск : БГУИР, 2007 . – 74с.

ISBN

Целью данного пособия является развитие навыков чтения и понимания оригинальных английских и американских текстов по техническим специальностям.

Пособие состоит из 8 разделов, каждый из которых включает краткий тематический словарь, тексты и задания к ним.

Предназначено для работы в аудитории под руководством преподавателя.

УДК 811.111(075.8)  
ББК 81.2 Англ 73

ISBN

© УО «Белорусский государственный университет  
информатики и радиоэлектроники», 2007

## CONTENTS

<b><u>UNIT 1</u></b> .....	4
<b><u>Part A.</u></b> THE FUTURE OF INFORMATION TECHNOLOGY .....	4
<b><u>Part B.</u></b> LICENCE TO CHILL.....	7
<b><u>Part C.</u></b> ANANOVA.....	9
<b><u>UNIT 2</u></b> .....	10
<b><u>Part A.</u></b> PROTECTION OF INFORMATION.....	10
<b><u>Part B.</u></b> COMPUTER CRIMES.....	15
<b><u>Part C.</u></b> COMPUTER SYSTEMS AND PROTECTION OF INFORMATION.....	18
<b><u>UNIT 3</u></b> .....	19
<b><u>Part A.</u></b> INTRODUCTION TO MOBILE COMMUNICATIONS.....	19
<b><u>Part B.</u></b> THE RISE AND RISE OF MOBILE PHONES.....	23
<b><u>Part C.</u></b> Text C .....	26
<b><u>UNIT 4</u></b> .....	27
<b><u>Part A.</u></b> RESEARCHERS DEVELOP NEW CHIP-MAKING TECHNIQUE....	27
<b><u>Part B.</u></b> NEW CHIP PRODUCES REAL-TIME, HIGH-QUALITY GRAPHICS. ....	31
<b><u>Part C.</u></b> Text C .....	34
<b><u>UNIT 5</u></b> .....	36
<b><u>Part A.</u></b> SUPPORT A SAFE INTERNET: SECURE YOUR SITE.....	36
<b><u>Part B.</u></b> WHO WRITES COMPUTER VIRUSES?.....	40
<b><u>Part C.</u></b> Text C.....	42
<b><u>UNIT 6</u></b> .....	43
<b><u>Part A.</u></b> ADVANCED SENSORS FOR MULTIFUNCTIONAL APPLICATIONS.....	43
<b><u>Part B.</u></b> BULK AND SURFACE ACOUSTIC WAVE SENSORS.....	46
<b><u>Part C.</u></b> Text C .....	49
<b><u>UNIT 7</u></b> .....	50
<b><u>Part A.</u></b> COMPUTER COMMUNICATIONS.....	50
<b><u>Part B.</u></b> BROADBAND COMMUNICATIONS.....	56
<b><u>Part C.</u></b> WHAT IS GPS?.....	59
<b><u>UNIT 8</u></b> .....	62
<b><u>Part A.</u></b> COMPUTED TOMOGRAPHY.....	62
<b><u>Part B.</u></b> Text B.....	66
<b><u>Part C.</u></b> MAGNETIC RESONANCE IMAGING (MRI).....	68

## UNIT 1

### Part A

#### Word List

catch up	/kætʃ/	подхватить, догнать, нагнать
convergence	/kən'vɜ:dʒəns/	схождение, совпадение, совмещение
extraterrestrial	/,ekstrətə'restriəl/	1) внеземной, космический 2) обитатель космоса
feedback loop	/'fi:dbæk lu:p/	цепь, петля обратной связи
involvement	/in'vɒlvmənt/	вовлечение
midst	/mɪdst/	середина
noticeable	/'nəʊtɪsəbl/	заметный, приметный
offspring	/'ɒfsprɪŋ/	потомок
recognition	/,rekəg'nɪʃn/	узнавание, признание, одобрение
smart	/smɑ:t/	умный, сообразительный
ultimately	/'ʌltɪmətli/	в конечном счете

*I. Study the following words and choose:*

*a) nouns*

- 1 converge, convergence, convergent, converging
- 2 application, applied, applicable, apply
- 3 expect, expectant, expectance, expectative, expectation
- 4 assistance, assist, assistant, assisting
- 5 provided, provide, provision, provider

*b) adjectives*

- 1 noticeable, notice, noticeably, noticing
- 2 advanced, advancement, advance, advancing
- 3 improvement, improved, improve, improvable
- 4 electronics, electron, electronically, electronic
- 5 recognize, recognition, recognizable, recognizance

*II. Arrange the words of the two groups in pairs with:*

*a) similar meaning*

- |               |               |
|---------------|---------------|
| 1 noticeable  | a intelligent |
| 2 continue    | b obvious     |
| 3 assistance  | c sphere      |
| 4 application | d data        |
| 5 converge    | e help        |
| 6 improve     | f supply      |
| 7 field       | g link up     |
| 8 smart       | h request     |
| 9 information | i make better |

- |                            |             |
|----------------------------|-------------|
| 10 provide                 | j carry on  |
| <i>b) contrary meaning</i> |             |
| 1 converge                 | a minor     |
| 2 positive                 | b slowly    |
| 3 near                     | c difficult |
| 4 rapidly                  | d distant   |
| 5 different                | e possible  |
| 6 never                    | f negative  |
| 7 ultimately               | g diverge   |
| 8 impossible               | h at first  |
| 9 easy                     | i always    |
| 10 major                   | j same      |

*III. Match the words with their definitions.*

- |                           |   |
|---------------------------|---|
| 1 interface               | a having a fear or strong dislike of technology and technological devices                           |
| 2 technophobic            | b the hardware or software that connects two systems and allows them to communicate with each other |
| 3 equivalence             | c the fact that you are taking part in something  |
| 4 ultimately              | d during all of the night   |
| 5 involvement             | e the experience of recognizing someone or something  |
| 6 solve                   | f to find a solution or an answer to a problem  |
| 7 skill                   | g the study and practice of techniques or use of equipment for dealing with information             |
| 8 recognition             | h the same use, function, size or value of two things   |
| 9 overnight               | i finally, after a long and complicated series of events  |
| 10 information technology | j the knowledge and ability that enables you to do something well                                   |

*IV. Study the text and try to understand all details.*

### **THE FUTURE OF INFORMATION TECHNOLOGY**

1. We are in the midst of convergence. At the hardware layer, computers, phones and consumer electronics are converging. At the applications layer, we see convergence of information, entertainment, communications, shopping, commerce, and education.

2. Computers have come from nowhere 50 years ago and are rapidly catching up in capability with the human brain. We can expect human: machine equivalence by about 2015. But after this, computers will continue to get smarter. There is a noticeable positive feedback loop in technology development, with each generation of improved computers giving us more assistance in the design and development of the next.

Ultimately, they will design their offspring with little or no human involvement. This technology development will push every field of knowledge forwards, not just

computing. It will be almost as though extraterrestrials had landed in 2020 and given us all their advanced technology overnight.

3. But we will never get far unless we can solve the interface problem. In the near future we may have electronic pets, with video camera eyes and microphone ears, linked by radio to the family computer. With voice and language recognition we will have easy access to all that the Internet can provide. We can tell the pet what we want and it will sort it out for us. It will be impossible to be technophobic about such an interface, and the only Information Technology skill needed will be to speak any major language.

*V. Read paragraph 1 of the text and say how the author justifies his claim that we are 'in the midst of convergence'.*

*VI. Read paragraph 2 and answer these questions:*

- 1 What features will computers have after 2015?
- 2 What does the author mean by a 'positive feedback loop' in computer development?

*VII. Look through paragraph 3 and find English equivalents of the following words and word combinations: решать, иметь легкий доступ, главный, обеспечивать, мастерство, узнавание, соединенный, рассортировывать.*

*VIII. Say whether the following statements are true or false.*

- 1 Divergence occurs at different layers.
- 2 Computers will become more and more intelligent.
- 3 The solution of the interface problem is very important.
- 4 We'll manage to create electronic pets soon.
- 5 The only Information Technology skill needed will be to speak many different languages.
- 6 There is no difference between computers and humans nowadays.

*IX. Complete the following sentences choosing the most suitable variant.*

- 1 Computers will continue to get...
  - a smaller
  - b smarter
  - c cheaper
- 2 By about 2015 we can expect human:...
  - a technology development
  - b substantial assistance
  - c machine equivalence
- 3 There is a noticeable positive ... .. in technology development...
  - a information convergence
  - b human brain capability
  - c feedback loop
- 4 With voice and language recognition we will have easy access to...
  - a all that the Internet can provide

- b the interface problem
  - c advanced technology
- 5 The technology development will...
- a provide access to the Internet
  - b push every field of knowledge forwards
  - c destroy humanity by very powerful computers

X. Read the fourth sentence of paragraph 2 and mark pauses. Divide it into sense groups, find out the means of connection between these sense groups and between the words in each group.

XI. Translate paragraph 2 into Russian.

XII. Make an outline of the text.

XIII. Speak about the future of Information Technology.

## Part B

I. Define the meaning of the "x" word.

- rely: reliability=полагаться:X
- addition: additional=сложение:X
- indicate: indicative=указывать:X
- equip: equipment=оборудовать:X
- place: replace=помещать:X
- exceed: exceedingly=превышать:X
- use: usage=использовать:X
- suggest: suggestion=предлагать:X
- include: inclusion=включать:X

II. Find in the list the following parts of speech: a) nouns, b) adjectives, c) adverbs, d) verbs.

Distance, frequency, include, totally, additional, reliability, nutritional, exceed, throw, fancy, different, require, usually, sensitive, suggest, assumption, textual, receive, favourite, surveillance, finally, perform, management, normally, send, great, relatively, limit, widen.

III. Complete the sentences with the following words:

provides	replaced	equipped	surf
interfaced	connected	include	

- 1 Barcodes in the packaging of groceries will soon be ... with radio-frequency tags.
- 2 The data in the tags will ... additional information.
- 3 A touch-sensitive panel or screen ... a means of communicating with the users.
- 4 The fridge is ... with a microphone.
- 5 The fridge is ... to the Internet.
- 6 You could ... the Web to find a new recipe.

7 The Screenfridge can be ... to a surveillance camera.

*IV. Read the text and define its main idea.*

### **LICENCE TO CHILL**

Barcodes (штриховой код) in the packaging of groceries will soon be replaced with radio-frequency tags that can be read at a distance and with greater reliability. As well as indicating what the product is, the data in the tags will include additional information such as 'best before' date and even nutritional data. Now, imagine that a fridge could read these tags and keep track of the items placed there.

If an item is about to exceed its 'use by' date, the fridge tells you, and you can either use it or throw it out. Fancy something different for dinner? No problem, ask the fridge to suggest some menus based on the ingredients it knows you have in stock. Or tell the fridge the menu you require and it will provide you with a shopping list of the items you don't have or order the items via email. This is the Screenfridge from Electrolux.

But why 'Screenfridge'? On the door is a touch-sensitive panel or screen that provides a means of communicating with the users. For many households, life revolves around the kitchen. This is the assumption Electrolux made in designing the Screenfridge. The same screen is a messaging centre. Since the fridge is equipped with a microphone, speaker and video-camera, you're not limited to textual information. The fridge is connected to the Internet, so it can be used to send and receive email or you could surf the Web to find a new recipe.

Many people have a TV in the kitchen, but if you already have a screen on the fridge, why clutter up the work surface with a TV? Call the Screenfridge's TV mode and watch your favourite programme on the fridge. The Screenfridge can be interfaced to a surveillance camera to check out visitors or to keep an eye on the children. Finally, the Screenfridge can perform some of the household management tasks normally associated with a PC. For example, it has a diary, address pad and a notepad.

*V. Say if the following statements are true or false.*

- 1 Radio-frequency tags will soon be used instead of barcodes in the packaging of groceries.
- 2 You can read radio-frequency tags with less reliability.
- 3 The information in the tags is limited.
- 4 A touch-sensitive panel allows communicating with the users.
- 5 It's impossible to use the fridge for sending and receiving email.
- 6 Screenfridge can perform many different functions.

*VI. Divide the text into logical parts and find the topical sentences in each part.*

*VII. Give a short summary of text B.*



## Part C

*I. Look at the title. What do you think this reading will be about? Read the text and define its main idea.*

### ANANOVA

Ananova is the world's first digital newsreader. She was created to front an Internet 24 hours a day news service by Digital Animations Group, a Scottish 3D digital entertainment company and PA New Media.

Mark Hird, Director of PA New Media said, 'We have given her a full range of human characteristics after researching the personality most people want to read news and other information. Ananova has been programmed to deliver breaking news 24 hours a day via the Internet, and later on mobile phones, televisions and other digital devices.'

The Ananova character fronts a computer system, which is constantly updated with news, sport, share prices, weather and other information. This is converted into speech while another program simultaneously creates real-time animated graphics. This ensures that the virtual newscaster can be on top of the news as it breaks, with very little delay at all. People using the service can also tailor their own news bulletins by using search words to hear the latest information on their chosen subjects.

Mr Hird believes the invention will dramatically change the role of the traditional newscaster, 'In 20 years time we could be seeing that type of job being replaced by computer-generated images.' But not everyone agrees. Professor Bill Scott said that people prefer people to teach them things and in a world where information was increasingly important, an established face was important in terms of public trust. 'You don't get that confidence with computer characters.'

*II. Read the text and answer the questions.*

- 1 What is Ananova?
- 2 What is Ananova used for?
- 3 Who created Ananova?
- 4 What does Ananova deliver?
- 5 In what way does Ananova deliver breaking news?

*III. Find the containing different opinions about this invention.*

*IV. Give the main points of the text in 5-6 sentences.*

## UNIT 2

### Part A

#### Word List

appropriate	/ə'prəʊpriət/	подходящий, соответствующий
counterfeit	/'kauntəfɪt/	подделка
distortion	/dɪ'stɔ:ʃn/	искажение, извращение (фактов)
envisage	/ɪn'vɪzɪdʒ/	предусматривать
heredity	/hə'redɪti/	наследственность
intend	/ɪn'tend/	намереваться
juridical	/dʒʊə'rɪdɪkl/	юридический, законный
lack	/læk/	недостаток, нужда, отсутствие
leak	/li:k/	течь, утечка
legislation	/,ledʒɪs'leɪʃn/	законодательство
particular	/pə'tɪkjələ(r)/	особый, особенный
peculiar	/pɪ'kju:liə(r)/	специфический, особенный
penetration	/,penɪ'treɪʃn/	проникновение, проницаемость
punish	/'pʌnɪʃ/	наказывать, карать, налагать взыскание
purchase	/'pɜ:tʃəs/	покупать, приобретать
subject	/sʌb'dʒekt/	подчинять, подвергать
theft	/θeft/	воровство, кража
threat	/θret/	угроза
treatment	/'tri:tmənt/	обращение, обработка
violate	/'vaɪələt/	нарушать, попирать

I. Study the following words and choose:

a) nouns

- 1 imply, implicit, implied, implication
- 2 permit, permission, permissible, permissibility
- 3 custom, customizable, customary, customer
- 4 responsible, respond, responsibility, response
- 5 property, proper, propertied, properly

b) verbs

- 1 possessive, possessor, possession, possess
- 2 appear, appearing, appearance, appeared
- 3 penetration, penetrative, penetrate, penetrability
- 4 punished, punish, punishable, punishment
- 5 abuse, abusive, abusiveness, abused

*II. Arrange the words of the two groups in pairs with:*

*a) similar meaning*

- |    |            |   |           |
|----|------------|---|-----------|
| 1  | purpose    | a | carry out |
| 2  | support    | b | harm      |
| 3  | qualified  | c | define    |
| 4  | conduct    | d | defence   |
| 5  | provide    | e | enlarge   |
| 6  | protection | f | supply    |
| 7  | sphere     | g | target    |
| 8  | damage     | h | skillful  |
| 9  | increase   | i | branch    |
| 10 | doubt      | j | maintain  |
| 11 | determine  | k | hesitate  |
| 12 | abuse      | l | insult    |

*b) contrary meaning*

- |    |              |   |               |
|----|--------------|---|---------------|
| 1  | appear       | a | sanctioned    |
| 2  | obtain       | b | purchase      |
| 3  | increasing   | c | near          |
| 4  | employer     | d | inappropriate |
| 5  | public       | e | lose          |
| 6  | sell         | f | escape        |
| 7  | harm         | g | decreasing    |
| 8  | remote       | h | private       |
| 9  | appropriate  | i | use           |
| 10 | unsanctioned | j | employee      |
| 11 | permit       | k | forbid        |

*III. Match the words with their definitions.*

- |    |             |   |   |
|----|-------------|---|---|
| 1  | abuse       | a | to make something happen  |
| 2  | distortion  | b | damage, injury  |
| 3  | personnel   | c | give or make a suggestion   |
| 4  | challenge   | d | unwanted change of shape or a signal  |
| 5  | property    | e | break in without right or invitation  |
| 6  | harm        | f | staff; persons employed in any work;  |
| 7  | security    | g | invitation or call to play a game, run a race, have a fight to see who is better, stronger, etc |
| 8  | interfere   | h | to have as a part of another thing  |
| 9  | cause       | i | turn to, go to, for information   |
| 10 | legislation | j | wrong use   |
| 11 | include     | k | safety, freedom from danger or anxiety  |
| 12 | imply       | l | things owned; possessions   |
| 13 | refer to    | m | making laws; the laws made  |

*IV. Study the text and try to understand all details.*

## **PROTECTION OF INFORMATION**

1. Rapid development of automation processes and the penetration of the computers in all fields of life have led to appearance of a range of peculiar problems. One of these problems is the necessity of providing effective protection to information and means of its processing.

2. A lot of ways to access information, considerable quantity of qualified specialists, vast use of special technical equipment in social production make it possible for violators practically at any moment and in any place carry out the actions, which represent a threat to information safety.

3. Particular role in this process has been played by appearance of personal computer (PC), which has made computers, software and other informational technologies available to general public. Wide distribution of PC and impossibility of conducting effective control of their use have resulted in the decreasing security level of information systems.

In the current situation, data processing has moved the problems of information security forward to the rank of most important problems of national economy. Solving the problem of poor information security presupposes a complex of measures. First of all, such actions of government as development of classification system, documentation of information and protection methods, data access regulations and punishing measures against information security violators.

### **State informational sources**

4. Formation of state informational sources is carried out by citizens, state authorities, organizations and social unions. Documents, which belong to a person, can be included in the state structure of informational sources, of course, if the person wishes. State informational sources are open and generally available. Documented information with limited access is divided into state secret and confidential information.

### **Citizen information (personal information)**

5. Personal data refers to confidential information. The collection, storage, use and distribution of private information are not allowed. The information, which breaks personal and family secret, secret of correspondence, telephone, postal, telegraph talks and other messages of a person without his/her permission, is also confidential. Personal data may not be used with purpose of causing damage to person's property and reputation, difficulties of realization its right. Collected data must be limited to necessary information. The information, which carries strong probability of causing damage to a citizen's interests shouldn't be collected.

There are some categories of personal information:

- secret documents;
- official department rules and instructions;
- information, which is not to be made public in accordance with legislative acts;
- confidential business information;

- information, which touches private life of a person;
- information of financial institutions;

### **Development and production of informational systems**

6. All types of informational systems and networks, technologies and means of their providing compose a special branch of economic activity, whose development is defined by the state scientific, technological and industrial policy of informatization.

State and non-state organizations and, of course, the citizens have equal rights in terms of access to the development and producing of informational systems, technologies.

### **Owner of informational systems**

7. The informational systems, technologies and means of their providing can be the property objects of juridical person, non-juridical person and state. The owner of informational system is a person, who purchased these objects or got as a gift, heredity or by any other legal way. The informational systems, technologies and means of their providing can be considered as a good (product), if the producer rights are not broken. The owner of informational system determines the using conditions of this product.

### **Copyrights and property rights**

8. Copyrights and property rights on informational systems, technologies and means of their providing can be belong to different persons. The owner of informational systems has to protect copyrights in accordance with legislation. Informational systems and databases, intended for citizens' and organizations' informational service, are subjected to certification according to the established custom. The organizations, which work in the field of making design, producing the means of information protection and personal data treatment, must obtain licenses to conduct such activity. The steps for obtaining license are defined by the legislation.

*V. Read the third sentence from the beginning and mark pauses. Divide it into sense groups, find out the means of connection between these sense groups and between the words in each group.*

*VI. In paragraphs 1-3 find English equivalents of the following words and word combinations: представлять угрозу информационной безопасности, предлагает комплекс мер, способы защиты, средства обработки, широкое распространение ПК, решить проблему, штрафные меры, осуществлять эффективный контроль, нарушители информационной безопасности, общественное производство, проникновение компьютеров во все сферы жизни, необходимость обеспечить эффективную защиту.*

*VII. Read paragraph 5 and answer the questions.*

- 1 What information is considered confidential?
- 2 How may personal data be used?
- 3 What are the categories of personal information?

*VIII. In paragraph 8 find the information about copyrights and render it to your partner.*

*IX. Say whether the following statements are true or false.*

- 1 State organizations have more legal rights than non-state ones in terms of access to the development and producing of informational systems, technologies.
- 2 Documents which belong to a person can be included in the state structure of informational sources if it is necessary for the state.
- 3 The owner of informational systems is a person who got it by any legal way.
- 4 Informational systems and databases, intended for citizens' and organizations' informational service, are not obligatory subjected to certification.
- 5 The informational systems, technologies and means of their providing can be considered as a good.
- 6 The organizations, which work in the field of making design, producing the means of information security and personal data must obtain licenses.

*X. Complete the following sentences choosing the most suitable variant.*

- 1 The development of computer technology has moved the problems of information security to the rank of ...
  - a most serious problems of industrial policy
  - b most important problems of national economy
  - c most significant problems of economic activity
- 2 The collection, storage, use and distribution of private information ...
  - a are permitted for employers
  - b are carried out by state institutions
  - c are not allowed by the law
- 3 The development of data processing technology has led to the appearance of ...
  - a official department rules and instructions
  - b information of financial institutions
  - c the necessity of providing effective protection to information
- 4 The fact of great number of computer users means ...
  - a the definite risk to security
  - b poor quality of processing of information
  - c slower access to data resources
- 5 The organizations, which work in the field of making design, producing the means of information protection and personal data treatment must ...
  - a determine the using conditions of their product
  - b use new informational services at homes
  - c obtain licenses to conduct such activity

*XI. Make an outline of the text.*

*XII. Speak about the significance of protection of information.*

## Part B

I. Look through the list of English words and their Russian equivalents facilitating reading text B.

abuse	/ə'bjʊ:s/	злоупотребление, неправильное употребление
alarm	/ə'la:m/	смятение, страх
challenge	/'tʃæləndʒ/	вызов; сложная задача, проблема
collusion	/kə'lu:ʒn/	сговор, тайное соглашение
commit	/kə'mɪt/	совершать
consequence	/'kɒnsɪkwəns /	следствие; вывод, заключение
employ	/ɪm'plɔɪ/	нанимать; предоставлять работу
engage	/ɪn'geɪdʒ/	нанимать; занимать
espionage	/'espɪənə:ʒ/	шпионаж, шпионство
extortion	/ɪk'stɔ:ʃn/	вымогательство
imply	/ɪm'plaɪ/	подразумевать, намекать
swindle	/'swɪndl/	жульничество, мошенничество

II. Define the meaning of the "x" words.

admit: admitting = допускать: X

enrich: enrichment = обогащать: X

interfere: interference = вмешиваться: X

sure: ensure = уверенный: X

maintain: maintenance = поддерживать: X

law: unlawful = закон: X

intend: intentional = намереваться: X

considerable: considerably = значительный: X

III. Complete the sentences with the given words:

defined                      informational      protected                      causing                      unlawful  
computer                      processing                      by means of                      fulfilled                      collusion

- 1 Computer crime is any action ... by means of electronic data ... system or against it.
- 2 The organizations that use ... technologies and people who use new ... services at homes are worried most of all.
- 3 The most danger can represent such specialists who are in ... with managers of commercial structures.
- 4 The criminal has the opportunity of penetration to the ... systems ... remote access.
- 5 Computer crime can also be ... as all intentional and ... actions, which lead to ... harm to possessions.

IVI. Study the following words and choose:

a) adjectives

- 1 probably, probability, probable
- 2 order, orderly, orderliness
- 3 intention, intentional, intent
- 4 doubt, doubted, doubtful
- 5 consideration, considerable, considerably
- 6 consideration, considerable, considerably

b) adverbs

- 1 safety, safely, safe
- 2 official, officially, officious
- 3 widen, width, widely
- 4 gradually, gradation, gradient
- 5 complete, completion, completely
- 6 relate, relative, relatively

V. Read the text and define its main idea.

## **COMPUTER CRIMES**

The development of computer technology and its wide use have led to appearance and spread of computer crimes. Such situation causes alarm among those organizations and legislative institutions that use computer technologies and, of course, people, who use new informational services at homes.

The term "computer crime" was first used in the early 70s. However, the discussions concerning it are still actual. The top question of these discussions is "What unlawful actions are implied by computer crime". A rank of definitions of the computer crime has been composed. It often refers to crimes directly or indirectly connected to electronic computing machines and which includes a number of illegal acts, committed by means of electronic data processing system or against it. Others consider that computer crime is any action, which goes together with interfering with property rights and fulfilled by means of computers. The thirds think that computer crime can be defined as all intentional and unlawful actions, which lead to causing harm to possessions, with help of computers too.

There are following forms of computer criminality: computer manipulations, economic espionage, sabotage, computer extortion, "hackers" activity. The main character of committing computer crimes in the business field becomes highly qualified "white collars" from the suffered organization's employees.

According to the MIS Traiding Institute (USA), they get 63% of all causes, examining crimes and abuses. More than 36% of law-committing employees are related to the personnel, which is not connected with computer servicing, 29% - qualified programmers, 25% - other workers of computing center. This tendency is reflected in official statistics too, according to which, about 40% of computer crimes are committed for solving of financial problems, 20% are motivated as an intellectual



challenge to society, 17% - by the willing of solving personal problems, 8% - problems of corporation or organization, 4% - are directed for social admitting, 3% - for wounding somebody's rights and so on.

The most dangerous individuals of computer swindle are so called "hackers", "crackers" and representatives of other groups, working in the sphere of industrial espionage. So, many security specialists advise employers to pay special attention to engaged workers-specialists in computer technologies, programming and information protection spheres.

There are many causes, when "hackers" get a job with a goal of personal enrichment. But the most danger can represent such specialists, who are in collusion with managers of commercial structures and organized criminal groups; in these situations causing damage and weight of consequences considerably increases.

There are two types of unsanctioned access:

- internal "breaking open" – the criminal has access to the terminal, with information he interested in and can work with it for some time without somebody's control;
- external "breaking open" – the criminal doesn't have indirect access to the computer system, but has an opportunity of penetration to the protected system by means of remote access;

Analysis of such actions shows that single crimes from own or neighbour work places gradually develop into network computer crimes, which are carried out by means of breaking of organizations' protecting systems.

Therefore, the importance of information protection can not be doubted. I think, every organization should have a high-quality protection system in order to insure its safety. However, not only companies and state institutions need information protection system but also general home users need information protection system and should maintain the security of their computers.

*VI. Answer the following questions on the text.*

- 1 What factors have led to the appearance and spread of computer crimes?
- 2 What does the term “computer crime” imply?
- 3 What are the forms of computer criminality?
- 4 What are the reasons of committing computer crimes?
- 5 Who is the main character of computer crimes?
- 6 What should be done to reduce the danger?

*VII. Match parts of the sentences in columns A and B.*

A		B	
1	About 40% of computer crimes are committed for ...	a	single crimes have gradually developed into network computer crimes.

2	Some “hackers” get a job with ...	b	engaged workers-specialists in computer technologies, programming and information protection spheres.
3	General computer users should maintain ...	c	a goal of personal enrichment.
4	Analysis of such actions shows that ...	d	solving of financial problems.
5	Employers are advised to pay special attention to ...	e	the security of their computers.
6	The most danger can represent such specialists, who are...	f	in collusion with managers of commercial structures and organized criminal groups.

*VIII. In each logical part of the text find topical words and phrases and make up an outline of the text.*

*IX. Give a short summary of the text according to the plan.*

### **Part C**

*I. Read the following text and define its main ideas.*

#### **COMPUTER SYSTEMS AND PROTECTION OF INFORMATION**

The problem of information security is relatively new. Not all problems, connected with it have been figured out and solved up to now. The fact of great number of computer systems users means the definite risk to security because not all clients will carry out the requirements of its providing.

The order of storage mediums should be clearly defined in legal acts and envisage the complete safety of mediums, control over the work with information, responsibility for unsanctioned access to mediums with a purpose of copying, changing or destroying them and so on.

There are some legal aspects of information protection, which can appear due to not carefully thought or ill-intentioned use of computer technics:

- legal questions of protection of informational massifs from distortions;
- security of stored information from the unsanctioned access;
- setting juridically fixed rules and methods of copyrights protection and priorities of software producers;
- development of measures for providing the juridical power to the documents, which are given to the machines;
- legal protection of the experts' interests, who pass their knowledge to the databases;
- setting of legal norms and juridical responsibility for using electronic computer means in personal interests, which hurt other people and social interests and

can harm them;

The lack of appropriate registration and control, low level of work and production personnel discipline, the access of any unauthorized person to the computing sources create conditions for abusing and cause difficulties to their detection. In every computing center it is usual to set and strictly follow the regulations of the access to different official rooms for employees of any categories.

The main purpose of information protection is preventing from the leak, theft, distortion, counterfeit of information; preventing the threat to person's life and social safety, protection of the constitution and so on. The information is subjected to protection, when it may cause the harm for its owner, user or other person.

*II. Read the text and answer the questions.*

- 1 Why is the problem of information security difficult to solve?
- 2 What aspects should legal acts on information protection include?
- 3 What creates conditions for violations in this sphere?
- 4 What is the main purpose of information protection?

*III. Give the main points of the text in 5-6 sentences.*

## UNIT 3

### Part A

### Word List

airtime	/ 'eətaɪn/	эфирное время
capacity	/ kə'pæsəti/	емкость, способность
CDMA (a code-division multiple access technology)		технология множественного доступа с разделением кода
decline	/ dɪ'klaɪn/	уменьшаться, убывать
enormous	/ ɪ'nɔ:məs/	громадный, огромный
expansion	/ ɪk'spænfən/	рост, развитие, распространение, расширение
GSM (Global System for Mobile Communication)		глобальная система мобильной связи
multiple	/ 'mʌltɪpl/	многократный, многочисленный, множественный
spread	/ spred/	распространять(ся)
suggest	/ sə'dʒest/	предлагать
threat	/ θret/	угроза
TDMA (time-division multiple access system)		система с повременным делением

I. Study the following words and choose:

a) nouns

- 1 predict, prediction, predicting, predicted
- 2 increase, increasing, increasingly, increased
- 3 suggest, suggestively, suggestion, suggestive
- 4 attractable, attract, attractive, attractiveness

b) adjectives

- 1 access, accessible, accessibility, accession
- 2 compete, competitive, competitor, competition
- 3 reliability, rely on, reliable, reliably, reliance
- 4 expand, expansion, expansibility, expandable

II. Substitute the word in italics with a word below which makes the least change to the meaning of the sentence:

reliability	diminished	types	increase
forecast	characteristic	aim	benefits
provides	particularly	wide	ring/call

- 1 There has been a big *rise* in sales figures this year.
- 2 The main *purpose* of this exercise is to increase awareness of customer needs.
- 3 An important *feature* of this equipment is its weight.
- 4 It is difficult *to predict* out turnover in the next two years.
- 5 The market for hardware has *shrunk* appreciably.
- 6 You must be careful, *especially* when choosing the model.
- 7 There are many *advantages* in choosing the lightweight model.
- 8 There are many *kinds* of phone with sophisticated facilities.
- 9 Can you *phone* me in the morning?
- 10 We have a *broad* range of products and services available.
- 11 The most important thing in safety equipment is its *dependability*.
- 12 Our company *supplies* testing equipment for the electronics industry.

III. Use these words taken from the passage to complete the sentences which follow:

undergo	roaming	reliability	security	shrink
expansion	coverage	competition	on the move	

The extensive ... (a) allows us to use our phones almost anywhere. People who are often ... (b) benefit from mobile communications. We will ... (c) many changes next year.

...(d) of information is important in the defence industry. The ...(e) of the system is vital if we are to work in difficult conditions. In order to bring down prices, we need open ...(f) between a range of suppliers. The ...(g) of the market means a lot more potential customers. ...(h) allows us to travel freely in Europe with our mobile phone. Do you think the size of equipment will ... (i) below its present size?

*IV. Match the words with their definitions.*

1 air-time	a transforming the signal into a series of binary digits/bits
2 analogue	b a tendency/ a general move in one direction
3 digital	c a network based on an infrastructure of cables
4 competition	d a mobile system which uses digital technology and can be used in a number of European countries
5 coverage	e a network based on radio communications
6 fixed network	f to become smaller in size
7 mobile network	g the period when a mobile phone is switched on being used for speech
8 network operators	h transferring a call to another number
9 available	i using wave modulation sampling techniques
10 roaming	j a smartcard the size of a credit card or a stamp containing an individual subscriber's details
11 service provider	k a situation in which several companies offer similar services or products
12 shrink	l ready to be used
13 trend	m the area which can be reached
14 forward a call	n companies which build and operate telecom networks and their services
15 GSM	o the facility which allows a mobile phone user to use the same handset in different European countries
16 SIM (Subscriber Identity Module)	p companies which sell services through operators or dealers

*V. Study the text and try to understand all details.*

## **INTRODUCTION TO MOBILE COMMUNICATIONS**

1. Since its introduction in the late 1970s and early 1980s, mobile telephony has undergone an enormous expansion. As the size and weight of the mobile phone itself has shrunk, the networks have become more powerful, the market has grown and the cost of equipment and airtime has declined sharply. At the same time, the services available – such as voice banks, call forwarding and data transmission – have also increased the attractiveness of the product, especially for the business user. Much of the development has been due to the intense competition in the mobile market, which is less regulated than the fixed telephone market.

2. The two main types of technology in use are analogue and digital. The first systems to be introduced were analogue; these are still the most used, and they offer the widest coverage within most countries. Digital systems are a more recent introduction, and they are becoming increasingly common throughout the world. They have several advantages over analogue, notably their capacity, reliability and security. They also offer extra services, especially for business customers. In addition, although some analogue systems allow the user to “roam” within a certain

number of countries, digital systems give greater flexibility, which could soon include world-wide roaming.

3. GSM – Global System for Mobile communication – is the pan-European digital standard which is rapidly spreading throughout Europe and is also establishing itself as the standard in other parts of the world. The main threat to GSM comes from CDMA, a code-division multiple access technology which uses frequencies more economically than the time-division system (TDMA) used by GSM. The advantages of CDMA, a rapidly developing technology, may give it a competitive edge over GSM, especially in markets like the USA where the airwaves are already crowded. The general prediction is that digital systems, of whichever technology, will gradually take over from analogue systems, especially in the more developed markets. However, recent trends suggest that in established markets the transfer is happening more slowly than was forecast. If one system is widely adopted, the regular traveller can have just one mobile phone which she or he uses whilst on the move in a number of countries.

*VI. Read paragraph 1 of the text and answer the questions.*

- 1 What has mobile telephone undergone since its introduction?
- 2 Identify those things which have increased and those which have decreased in the world of mobile communications.
- 3 What services have increased the attractiveness of the product to the business user?

*VII. Read paragraph 2 and name the advantages of digital systems.*

*VIII. Look through paragraphs 1 and 2 and find English equivalents of the following words and word combinations.*

Преимущество, надежность, сокращать, уменьшать(ся), покрытие, хотя, мощность(емкость), огромный, чрезвычайно, эфирное время, внедрять.

*IX. Say whether the following statements are true or false.*

- 1 The fixed telephone market is more regulated than the mobile market.
- 2 The services available have increased the attractiveness of mobile systems.
- 3 Analogue systems are no longer used throughout the world.
- 4 The quality of mobile communications has improved because of technological development.
- 5 GSM is recognized as the universal digital standard in the world.
- 6 It is predicted that digital systems will replace analogue ones in the more developed markets.
- 7 TDMA applied by GSM uses frequencies more economically than CDMA.

*X. Complete the following sentences choosing the most suitable variant.*

- 1 Much of the development in the mobile market has been due to ...
  - a narrower coverage
  - b the intense competition

- c decreased marketing
- 2 GSM might be threatened by ...
  - a TDMA
  - b ISDN
  - c CDMA
- 3 Digital systems provide ...
  - a greater flexibility, reliability and higher security
  - b more capacity, greater clarity and more expensive equipment
  - c advanced services, smaller telephones and shorter battery life
- 4 In established markets the transfer from analogue to digital technology is taking place ...
  - a more quickly than it was forecast
  - b as quick as it was forecast
  - c not as quick as it was forecast

*XI. Read the second sentence of paragraph 3 and mark pauses. Divide it into sense groups, find out the means of connection between these sense groups and between the words in each group.*

*XII. Translate paragraph 3 into Russian.*

*XIII. Make an outline of the text.*

*XIV. Speak about the development of mobile communications and its advantages.*

## **Part B**

*I. Define the meaning of the "x" word:*

relatively: relative = X: относительный

execute: executive = X: служащий

emerge: emergence = X: появление

penetrate: penetration = X: проникать

prevail: prevalent = X: распространенный

provide: provision = X: обеспечение

approximate: approximately = X: приблизительно

particular: particularly = X: особенный

employ: employment = X: занятость

*II. Find in the list the following parts of speech: a) nouns, b) adjectives, c) adverbs, d) verbs.*

Necessary, customer, extensively, popularity, competition, network, communication, steadily, connection, enormously, successful, equipment, variety, frequency, attractive, commercial, potential, decision.

*III. Complete the sentences with the following words:*

rate	give way to	staggering
due to	range of choice	viable
trend	would be	prevalent

- 1 There has been a strong ... (a) towards miniaturization of equipment.
- 2 The increase in capacity in the last few years is quite ... (b).
- 3 The obsession with national interests must ... (c) international considerations.
- 4 Any ... (d) member of the club must first state his qualifications.
- 5 International competition has become very ... (e) over the last few years.
- 6 The tendency to work at home is ... (f) improved communications.
- 7 In order to make a good decision, you need a wide ... (g).
- 8 This scheme will be ... (h) only if it is properly supported.
- 9 The ... (i) of progress in this project has been excellent.

*IV. Read the text and say which paragraph contains the information about the predicted rate of increase in mobile connections by the year 2010.*

### **THE RISE AND RISE OF MOBILE PHONES**

After a relatively slow start, the use of mobile phones has grown at a staggering rate in the last few years. The “yuppie” image so prevalent in the UK and other European countries is giving way to the idea, long held in Scandinavia, that the mobile phone is a necessary part of everyday life. Customers fall into three broad groups: business executives, sales staff, and self-employed people such as builders and electricians. These are people who travel extensively and for whom communication means keeping in touch, getting business and providing service.

The growth in popularity has been due partly to the fact that in most countries mobile communications have always been open to competition. The European Union will open up competition in fixed network telephony; but in mobile communications, most countries already have more than one network operator. In most cases the national operator has set up its own mobile network, but must compete against at least one other licensed operator. The number of national and international competitors is increasing steadily, even though some operators have tried and failed to set up a viable service.

One result of the increase in competition is that prices of systems and of terminal equipment and call charges are dropping rapidly as operators fight for the newly emerging market. Predictions are difficult to make, but analysts believe that, given the present trends, the number of mobile connections in Europe, which was some 4 million in 1991, will have reached 80 million by the year 2010. The world market is at present approximately four times greater than the European. Penetration varies enormously, from six subscribers per 100 people in the USA, to under one per 100 in China.

Growth has also brought its problems as well as its successes. Although competition has led to a large number of types of equipment and services, which



gives the customer a wide range of choice, the variety is sometimes so large that the would-be mobile user is left confused. Another problem which will probably grow in complexity is the allocation and use of frequencies. Technologies like CDMA which make a more efficient use of frequencies will be attractive, particularly in the developed countries. Difficult technical and commercial decisions will have to be taken in order to provide space for all potential customers.

*Note:* The Yuppies lap up the latest technology which helps them to simplify their lives. They think that all new telephone services are of great interest and they use their credit-cards to buy a variety of goods and services. They are convinced that they will be able to learn how to use the latest technology and are addicts of tele-shopping. The Yuppie group is mainly made up of men between the ages of 25 and 59, most of whom are executives or members of the liberal professions. They generally have university degrees, high salaries and know eleven telephone numbers off by heart.

V. *Say if the following statements are true or false.*

- 1 A mobile phone has become a total must for people in everyday life.
- 2 Competition is a minor factor in the growth of mobile communications.
- 3 One of the problems arising from growth in the mobile sector is shortage of frequencies.
- 4 Difficult decisions should be made to provide space for all would-be customers.
- 5 It is expected that the number of mobile connections in Europe won't decrease in the forthcoming years.

VI. *Choose the best answer: a, b or c to complete the sentences.*

- 1 Technologies like CDMA ....
  - a will be especially attractive in the developed countries
  - b won't involve any difficult or commercial decisions
  - c will hold potential users back
- 2 As a result of competition call charges ...
  - a are going up
  - b are declining quickly
  - c are stable
- 3 Operators fight for ...
  - a the new market
  - b the right to invest money in new technologies and equipment
  - c giving the customer a wide range of choice of mobile operators
- 4 The would-be mobile user is left confused because of ...
  - a exotic applications by CDMA
  - b a staggering rate in the use of mobile phones in the world
  - c a great variety of equipment and services provided

VII. *Divide the text into logical parts and find the topical sentences in each part.*

VIII. *Give a short summary of the text.*

## Part C

### I. Study the definitions of the following words and phrases:

talktime	the time when a mobile phone is being used to receive and transmit signals
standby	a situation in which a mobile phone is switched on and can receive calls
pocket phone	small, light handsets which run off batteries and are now the most popular of mobile models
‘user-friendly’	easy to use

### II. Read the following text and entitle it.

Telecommunications technology has for some time been like a number of islands. A telephone line, a cordless phone, a pager are all separate products, bought separately to do different things, usually in just one country – the country where they were bought. But as the technology develops and expands, it is increasingly shaped by the requirements of the user. If the user wants to be able to make a call, send a fax, receive data, even watch video in any country in the world, and using her own, portable equipment, then the job of technology is to make this possible. The European Telecommunications Standards Institute (ETSI) is working on Universal Public Telephony (UPT); the ITU is working on the Future Public Land Mobile Telecommunications System (FPLMTS). Their aim is to make the technologies converge, by bringing about the compatibility and interoperability of all the different types of network, and so making them accessible to users everywhere.

This idea of one network – or a number of interoperating networks – through which a small handset will give access worldwide to a whole range of services – is often referred to as PCN: Personal Communications Network.

Already it is easier for the international customer to keep constantly in touch:

- Within the fixed network, Intelligent Networks make it possible for a customer to be followed round the world simply by punching in a personal access code.

- The digitalization of the networks brings them closer together. Short-range Micro-Cellular Networks (MCNs) such as Mercury 1-to-1 in the UK; digital cordless PBXs; the simple radio technology of Telepoint – these all have mobility as their key aim, so their design has common characteristics.

- Digital technology can also offer more than just telephony: data, fax, even video are more and more easily transmitted. And services such as voice boxes and call forwarding are easily provided.

- The GSM network is rapidly expanding to cover other parts of the globe. It will be possible to integrate GSM with satellite telecommunication systems, thus making it available in any part of the world.

- The user equipment is increasingly ‘user-friendly’. To be this, it should fulfil several conditions: it should be light, small and inexpensive, and at the same time it should have long standby and talking time, and have access to all possible services. The ‘pocket phone’ which fits easily into the pocket is a good example at the

moment; the SIM (Subscriber Identity Module) card available in GSM is the ideal ‘tool’ – a small plastic card which can fit into a standard phone and access the network, and charge the cost to the cardholder’s account. A similar development is the Personal Digital Assistant – a watch-like digital communicator which until now has been limited to science fiction and spy stories. The time has not yet come when a traveller can communicate from anywhere to anywhere by means of a small piece of equipment in her pocket. But it is fast approaching.

*III. Find in the text:*

- a the two things that the customer is increasingly looking for
- b three ways of describing the idea of one generally accessible telecommunications system
- c the two things that networks need to have in order to be accessible worldwide
- d how Intelligent Networks make accessibility easier
- e two effects of digitalization
- f what GSM can easily combine with
- g three examples of mini terminals

*IV. Give the main points of the text in 5-6 sentences.*

## UNIT 4

### Part A

### Word List

accommodate	/ə'kɒmədeɪt /	приспособлять
advanced	/əd'vɑ:nst /	1) выдвинутый вперед; 2) передовой
approach	/ə'prəʊtʃ/	подход
circuitry	/'sɜ:kɪtri/	схемы
current	/'kʌrənt /	1) текущий; 2) (электрический) ток
decline	/di'klaɪn/	отклонять; отказывать(ся) от
eventually	/ɪ'ventʃʊəli/	в конечном счете; в итоге
explain	/ɪk'spleɪn /	объяснять
extend	/ɪk'stend/	1) простираться, тянуться; 2) расширять
extreme	/ɪk'stri:m/	1) крайний; 2) чрезвычайный
feature	/'fi:tʃə(r)/	особенность, характерная черта; признак, свойство; деталь
feature size		размер элемента
fine	/faɪn/	1) тонкий, изящный; 2) точный; 3) высокого качества
immersion	/ɪ'mɜ:ʃn/	1) погружение; осадка; 2) иммерсия
overall	/,əʊvər'ɔ:l/	полный; общий; предельный
pack	/pæk/	1) упаковывать; 2) заполнять

pattern	/pætɪn/	1) образец; шаблон; модель; 2) схема
predict	/prɪ'dɪkt/	предсказывать
refract	/rɪ'frækt/	преломлять (лучи света)
require	/rɪ'kwaɪə(r)/	1) приказывать; требовать; 2) нуждаться в чем-либо
retool	/,ri:'tu:l/	переоборудовать; оснащать новой техникой
yield	/ji:ld/	производить

*I. Study the following words and choose:*

*a) nouns*

- 1 fabric, fabricant, fabricate, fabrication, fabricated
- 2 resist, resistance, resistible, resistivity, resistless
- 3 material, materialistical, materiality, materialist, materialize
- 4 refract, refraction, refractional, refractive, refractor, refractoriness

*b) adjectives*

- 1 fracting, fraction, fractional, fracture, fractionary
- 2 typically, type, typical, typify, typing
- 3 generate, generation, generative, generator, generical
- 4 decline, declinatory, declinator, declinable, declination

*II. Arrange the words of the two groups in pairs with:*

*a) similar meaning*

- |            |               |
|------------|---------------|
| 1 produce  | a die         |
| 2 extend   | b progressive |
| 3 chip     | c avoid       |
| 4 tool     | d manufacture |
| 5 advanced | e quality     |
| 6 decline  | f expand      |
| 7 require  | g device      |
| 8 feature  | h foresee     |
| 9 predict  | i demand      |

*b) contrary meaning*

- |            |            |
|------------|------------|
| 1 increase | a solid    |
| 2 advanced | b cheap    |
| 3 liquid   | c failure  |
| 4 extreme  | d decrease |
| 5 extend   | e unusual  |
| 6 buy      | f mild     |
| 7 success  | g shorten  |
| 8 costly   | h sell     |
| 9 typical  | i backward |

*III. Match the words with their definitions.*

1 chip	a a repeated arrangement of lines, shapes, or colours etc.
2 refract	b a substance found in many rocks, used in making transistors chips for microprocessors, etc.
3 pattern	c the method of doing something skilfully
4 tool	d a very small piece of silicon, etc. made to work like a complex wired electric circuit
5 technique	e a tiny semiconductor device that controls a flow of electricity
6 lens	f the flow of electricity along a wire etc. or through something
7 transistor	g an object that helps you to do a particular job
8 silicon	h bend a ray of light at the point where it enters water or glass etc. at an angle
9 current	i a curved piece of glass or plastic used to focus things

IV. Study the text and try to understand all details.

### RESEARCHERS DEVELOP NEW CHIP-MAKING TECHNIQUE

1. Scientists have developed a proof-of-concept approach for extending current chip-making techniques so that manufacturers can produce semiconductors with smaller feature sizes without spending millions of dollars to radically retool their fabrication plants to accommodate different techniques.

2. IBM and JSR Micro, which supplies custom materials for the semiconductor- and electronic-device-fabrication industries, developed the new technique. It uses advanced lenses and new materials to create chips with feature sizes of 29.9 nanometers and, eventually, even smaller. Current microprocessors generally have 90-nm feature sizes. Smaller feature sizes would let manufacturers pack more transistors onto chips, thereby increasing their power without making them larger.

3. The new approach would extend the current techniques of using argon-fluoride lasers, as well as deep ultraviolet and high-index X immersion lithographies, to produce circuitry patterns on the photoresist that sits on the silicon.

4. Immersion lithography typically uses water, which has a 1.43 refracting index. The refracting index measures how much a light wave slows when passing through a liquid or lens. Light passing through a high-index material has a shorter wavelength, which lithography can tightly focus, thereby yielding finer feature sizes. Thus, the argon-fluoride laser, which has a 193-nm wavelength, can generate small feature patterns by passing through a lens and a liquid before reaching the photoresist. Using different liquids and lens materials could increase the overall refractive index, which would enable smaller feature sizes using today's lithography techniques, explained Mark Slezak, technical manager of JSR Micro's lithography group.

5. For the new approach, JSR supplied an organic liquid, which they declined to identify, that has a 1.64 refractive index. In addition, IBM used higher-density quartz lenses with a refractive index of 1.67, up from current lenses' 1.56. "This

shows that several more generations of immersion lithography are possible," said Bob Allen, manager of lithography materials for IBM's Almaden Research Center.

6. Chip experts had predicted that present lithography approaches working with current materials— which create microprocessors with 110-, 90-, and 65-nm features – would be unable to draw circuit patterns less than 40-nm, requiring a shift to far different techniques.

7. Aaron J. Hand, managing editor of *Semiconductor International* magazine, said the new manufacturing technique would still require chipmakers to make some changes to their fabrication plants and buy new tools. The technique's success will thus depend on how costly it turns out to be and whether IBM and JSR can make it work as more than just a proof-of-concept approach, Hand noted. In perhaps six or seven years, he continued, manufacturers will still have to move to next-generation techniques, such as extreme UV lithography, that would require extensive and expensive retrofitting of fabs.

*V. Read the first sentence of paragraph 1 and mark pauses. Divide it into sense groups, find out the means of connection between these sense groups and between the words in each group.*

*VI. In paragraphs 2-3 find English equivalents of the following words and word combinations: снабжать; технология; рисунки схем; усовершенствованный; создавать; позволять; современный; мощность; собирать; подход; кремний; размер элемента.*

*VII. Read paragraphs 4-5 and answer the questions.*

- 1 What does refracting index measure?
- 2 What can the argon-fluoride laser generate before reaching the photoresist?
- 3 How could materials increase the overall refractive index?
- 4 What did JSR and IBM use for the new approach?

*VIII. Read paragraphs 5 and 6 and say what chip experts had predicted towards lithography.*

*IX. Say whether the following statements are true or false.*

- 1 A new approach for extending current chip-making techniques makes it possible to produce semiconductors with smaller feature sizes.
- 2 The manufacturers will spend millions of dollars to radically retool their fabrication plants to accommodate new techniques.
- 3 Current microprocessors generally have 80-nm feature sizes.
- 4 The new approach would extend the current techniques of using argon-fluoride lasers.
- 5 The refracting index measures a length of a light wave.
- 6 The overall refractive index could be increased by using different liquids and lens materials.
- 7 Chip experts had predicted that present lithography approaches would be unable to draw circuit patterns less than 40-nm.

8 In six or seven years manufacturers will have to move to next-generation techniques, such as immersion lithography.

X. Complete the following sentences choosing the most suitable variant.

- 1 Scientists have developed a proof-of-concept approach for extending current chip-making techniques so that ...
  - a manufacturers can retool their fabrication plants
  - b manufacturers can produce new lasers
  - c manufacturers can produce semiconductors with smaller feature sizes
- 2 Smaller feature sizes would let manufacturers pack more transistors onto chips, thereby ...
  - a increasing their power without making them larger
  - b increasing their power making them larger
  - c increasing their weight without making them larger
- 3 The new approach uses new lenses and materials to create chips with...
  - a feature sizes of 29.9 nm and, eventually, even larger
  - b feature sizes of 29.9 nm and, eventually, even smaller
  - c feature sizes of 28.9 nm and, eventually, even smaller
- 4 Using different liquids and lens materials could increase ...
  - a the overall refractive index
  - b the optical index
  - c the fractional index
- 5 The new manufacturing technique would require chipmakers...
  - a to spend millions of dollars to retool their fabrication plants
  - b to continue their work without changes
  - c to make some changes to their fabrication plants and buy new tools

XI. Make an outline of the text.

XII. Speak about the new approach of chip-making techniques.

## Part B

I. Define the meaning of the "x" words:

absorb: absorption = поглощать: x

allow: allowance = позволять: x

digit: digital = цифра: x

function: functionality = функция: x

light: lighten = свет: x:

occur: occurrence = случаться: x

refract: refraction = преломлять: x

require: requirement = требовать: x

reflect: reflection = отражать: x

II. Complete the sentences with the given words:

approach	functionality	chip
yield	performance	execute

- 1 An ongoing trend in computing and communication technologies has been to deliver more ... in smaller, more convenient packages.
- 2 High-performance computing can now take place on a single ... .
- 3 Northwestern University's new lithography ... uses pens with sharp microscopic tips 20 nanometers in diameter.
- 4 These systems could ... malicious instructions inserted by a hacker into the data.
- 5 Companies are interested in the new chips because they provide a supercomputer's performance and ... in a small package.
- 6 Some of the new supercomputer-on-chip don't run as fast as Pentium processors, making them more energy efficient, but ... higher performance.

*III. Choose:*

*a) nouns*

- |   |            |            |             |            |
|---|------------|------------|-------------|------------|
| 1 | dedicatee  | dedicate   | dedication  | dedicatory |
| 2 | performer  | perform    | performance | performing |
| 3 | reflection | reflective | reflect     | reflex     |
| 4 | trace      | tracer     | tracery     | tracing    |

*b) verbs*

- |   |             |           |             |             |
|---|-------------|-----------|-------------|-------------|
| 1 | designing   | designate | designation | design      |
| 2 | execution   | execute   | executive   | executant   |
| 3 | imagination | image     | imagine     | imaginative |
| 4 | render      | rendering | rendezvous  | rendition   |

*c) adjectives*

- |   |            |             |             |            |
|---|------------|-------------|-------------|------------|
| 1 | alternate  | alternation | alternative | alter      |
| 2 | complicacy | complicate  | complex     | complexity |
| 3 | integrant  | integration | integrity   | integrate  |
| 4 | intensive  | intensify   | intense     | intension  |

*IV. Read the title and make your predictions about the content of the text.*

**NEW CHIP PRODUCES REAL-TIME, HIGH-QUALITY GRAPHICS**

German researchers have developed a chip that can render complex graphics in real time. The chip could allow individuals or small organizations to easily perform complex graphics work. Currently, they must either use a single computer, which takes a long time to produce sophisticated graphics, or they must spend the money to have a cluster of computers yield results quickly.

Saarland University scientists have developed an algorithm that lets a chip rapidly perform ray tracing. This approach is an alternative to the rasterization techniques—used in most of today's graphics chips—that convert mathematical and digital information into a matrix of pixels.



Ray tracing is a sophisticated approach that renders images in 3D environments by tracing the paths that light rays would take through a scene and calculating the reflection, refraction, or absorption that would occur when they hit an object. Unlike rasterization, ray tracing yields the information needed to compute shadows, reflections, and other effects necessary for high-quality images.

However, ray tracing is resource intensive and thus, with complex graphics, takes a long time to work on a single PC or requires a cluster of machines to produce quick renderings.

The Saarland researchers developed an algorithm and chip architecture that let a ray-tracing processor render simple graphics at 20 frames per second and complex scenes at 10 fps using a 66-MHz field-programmable gate array (FPGA).

This is a tenfold increase over previous Saarland ray-tracing chips and would let a PC render complex scenes—in which many elements frequently move or otherwise change—in real time. Multiple FPGAs could be combined to increase performance further, noted Saarland Professor Philipp Slusallek.

He said the chip's architecture is highly parallel and its dedicated circuits could execute the ray-tracing algorithms more quickly than a CPU could. The FPGAs were suitable for prototyping because of their programmability, he explained.

Now, Slusallek noted, the researchers are developing ray-tracing application-specific integrated circuits. He said the ASICs, although more expensive and complex to design and produce, would be faster and could host more functionality than the FPGAs. The researchers have already simulated an ASIC design that runs at more than 300 MHz, he added.

The Saarland team has shown that inexpensive hardware can support ray tracing with very impressive performance, according to Nathan Carr, a postdoctoral researcher at the University of Illinois at Urbana-Champaign. "The research gives a glimpse into where the future of graphics might lead," he added.

Researchers have spun off a company, mrace, to commercialize the new technology. Airbus, Daimler-Chrysler, Skoda Auto, and Volkswagen are already using Saarland ray-tracing software for design projects.

*V. Say if the following statements are true or false.*

- 1 English researchers have developed a chip that can render complex graphics in real time.
- 2 The chip could allow individuals or small organizations to easily perform complex graphics work.
- 3 Saarland University scientists have developed an algorithm that lets a chip rapidly perform ray tracing.
- 4 This approach is equal to the rasterization techniques which are used in most of today's graphics chips.
- 5 Ray tracing renders images in 3D environments.
- 6 Like rasterization, ray tracing yields the information needed to compute shadows, reflections, and other effects necessary for high-quality images.

VI. Match parts of the sentences in columns A and B.

A	B
1 Multiple FPGAs could be combined	a is highly parallel.
2 The chip's architecture	b to design and produce.
3 The FPGAs were suitable	c that runs at more than 300 MHz.
4 The researchers are developing	d for prototyping because of their programmability.
5 The ASICs are more expensive and complex	e to increase performance further.
6 The researchers have already simulated an ASIC design	f ray-tracing application-specific integrated circuits.

VII. Divide the text into logical parts and find the topical sentences in each part.

VIII. Give a short summary of text B.

**Part C**

I. Read the following text and entitle it.

1. Texas Instruments says it has developed the first system-on-chip that lets cellular phones play TV programs. When completed, TI's Hollywood processor would combine analog radio-frequency circuitry that acts as a receiver with digital chips that process signals – performing such functions as analog-to-digital conversion, demodulation, and error correction – and decode channels for viewing by users.

2. In a TI-based phone, Hollywood sends the processed material to the company's OMAP mobile-multimedia application platform, which provides the interface that Sets users select the desired content. OMAP also separates the desired content from all of the other material being transmitted, performs video and audio decoding and screen formatting, and sends data to the display driver, explained Bill Krenik, TI's wireless advanced architectures manager.

3. Integrating these functions in one processor eliminates the need for separate components. This is a "huge advantage," Krenik said, because offering these capabilities on one chip takes up less room, thereby enabling smaller phones, reducing power consumption, and lowering overall costs.

4. TI is using advanced technology, including state-of-the-art 90-nanometer feature sizes, in hopes of keeping Hollywood's cost below \$10 per chip when it's produced in high volumes for commercial purposes. Minimizing a cellular phone's costs is a critical factor in the competitive, price-sensitive mobile-handset market.

5. Krenik said advances in display technology will help spur adoption as color screens become more suitable for TV-quality images.

6. Several companies have announced they will produce content for TV-enabled cellular phones. For example, the Fox Entertainment Group and Vodafone

plan to distribute a series consisting of 24 minute-long *mobisodes* (mobile episodes) in 23 countries beginning later this month.

7. New data-oriented services such as TV, rather than traditional voice services, may help troubled cellular providers, Krenik noted. Higher cellular usage has increased carriers' voice-related costs, while stiff competition has led them to drop rates and give away or subsidize expensive handsets.

8. According to Krenik, providers would generate revenue by selling TV programming on a pay-per-view or subscription basis.

9. In two years, he said, about 70 percent of cellular phones will have built-in digital TV receivers. Analyst Neil Strother with InStat/MDR, a market research firm, said TV phones could find audiences among mass-transit users and young consumers with the time to watch programming on their handsets. However, Strother added, the key questions are, "Will people pay extra for these phones, and how much more will they pay to watch more television?"

10. TI says that Hollywood samples could be available by the end of this year and that chips could be ready for testing in 2006 and for sale the following year. The US Federal Communications Commission and other standards bodies are involved.

11. TV phones are currently being tested in Asia, and observers expect Asia and Europe to adopt the handsets before the US.

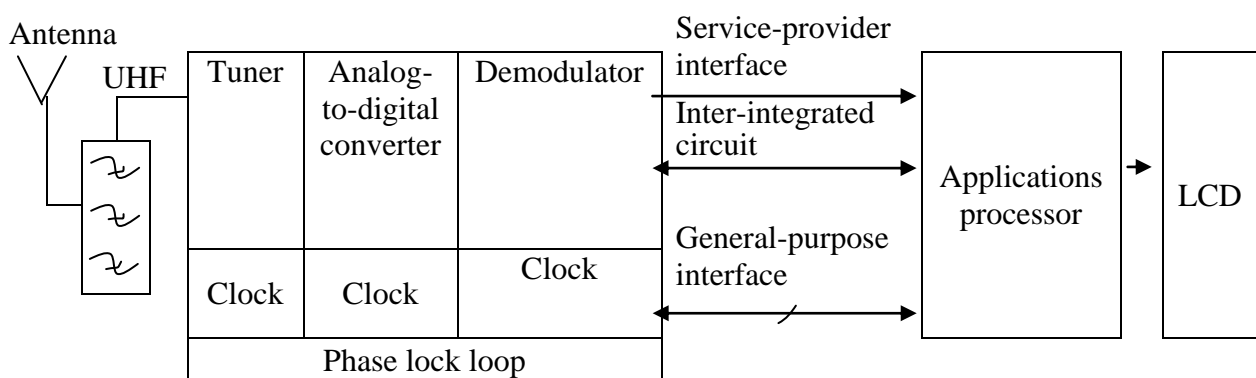

*Texas Instrument has developed a system-on-chip that lets mobile phones play TV shows. The chip's antenna receives the TV signal from a transmission tower. The tuner locks onto the signal and then tunes into the video feed. The analog-to-digital converter processes the video feed, which is demodulated into an MPEG stream. The applications processor then processes the stream and sends it to the LCD screen.*

## II. Answer the following questions on the contents of the text.

- 1 What has Texas Instrument developed?
- 2 What would TI's Hollywood processor combine, when completed?
- 3 What did Bill Krenik name a "huge advantage"?
- 4 What is a critical factor in competitive, price-sensitive mobile-handset market?
- 5 What will the advances in display technology help to do?

## III. Find the information about TI's Hollywood processor.

IV. Describe how a system-on-chip lets mobile phones play TV shows. Use the text and the given diagram.

V. Which paragraph contains information about the usage of TV phones in future?

VI. Give the main points of the text in 5-6 sentences.

## UNIT 5

### Part A

### Word List

authentication	/ɔː θentɪ'keɪʃn/	установление подлинности (документа, личности, объекта)
consideration	/kən sɪdə'reɪʃn/	рассмотрение, обсуждение
claim	/kleɪm/	1) требование; 2) иск, претензия
confirm	/kən'fɜ:m/	подтверждать, утверждать, поддерживать
corporate	/'kɔ:pərət/	общий, корпоративный
default	/dɪ'f ɔ:lt/	отсутствие, недостаток; невыполнение обязательств
encrypted	/ɪn'krɪptɪd/	зашифрованный, закодированный
firewall	/'faɪəwɔ:l/	межсетевой шлюз; аппаратные и программные средства
forgery	/'fɔ:dʒəri/	1) подделка, подлог; 2) фальшивый документ; подделанная подпись
fake	/feɪk/	подделка, фальсификация
insecurity	/ ,ɪnsɪ'kjʊərəti/	несоблюдение требований безопасности, отсутствие безопасности
identify	/aɪ'dentɪfaɪ/	опознавать, отождествлять
merely	/'mɪəli/	только, просто, единственно
outsider	/ ,aʊt'saɪdə(r)/	постороннее лицо; лицо, непричастное к системе
restrict	/rɪ'strɪkt/	ограничивать, заключать в пределы
raw	/rɔ:/	необработанный
session	/'seʃn/	сеанс (связи); сессия; совещание
share	/ʃeə(r)/	делить, разделять
signature	/'sɪgnətʃə(r)/	подпись, сигнатура, характерный признак

I. Study the following words and choose:

a) nouns

- 1 financier, finance, financial
- 2 transmit, transmissible, transmission

- 3 provided, provider, providing
- 4 installation, install, installment

*b) verbs*

- 1 identification, identify, identity, identical
- 2 confirmation, confirmative, confirmed, confirm
- 3 restrict, restricted, restriction, restrictive
- 4 creation, create, creative, creator

*c) adjectives*

- 1 sensibility, sensitive, sensitize, sensitivity
- 2 vitality, vitalize, vital, vitals
- 3 security, secure, Security Council
- 4 globe, global, globosity

*II. Arrange the words of the two groups in pairs with:*

*a) similar meaning*

- |               |                  |
|---------------|------------------|
| 1 request     | a mixture        |
| 2 secure      | b put one's name |
| 3 install     | c inquiry        |
| 4 select      | d defend         |
| 5 share       | e personal       |
| 6 sign        | f assemble       |
| 7 private     | g divide         |
| 8 combination | h choose         |

*b) contrary meaning*

- |                |                |
|----------------|----------------|
| 1 outside      | a internal     |
| 2 secure       | b destroy      |
| 3 sender       | c original     |
| 4 create       | d inside       |
| 5 limit        | e insecure     |
| 6 fake         | f decoding key |
| 7 encoding key | g extend       |
| 8 external     | h receiver     |

*III. Match the words with their definitions.*

- |                   |  |
|-------------------|--|
| 1 request         | a to write one's name on;  |
| 2 client          | b to take another person's property;   |
| 3 to sign         | c a secret word allowing a person to prove authorization to pass or enter;                       |
| 4 steal           | d the condition or fact of being the same as something else;                                     |
| 5 data processing | e a plan of action; a secret plot;   |
| 6 password        | f a course of travel;  |
| 7 identity        | g a reply; the act of replying;  |
| 8 scheme          | h the business of handling and storing information using computers and other available machines; |

9	route		i	to ask for something;
10	response		j	a person who secures the professional services of another;

*IV. Study the text and try to understand all details.*

### **SUPPORT A SAFE INTERNET: SECURE YOUR SITE**

1. Transmitting sensitive information, such as credit-card numbers or corporate financial data, across the Internet can be risky. By default, data that's sent across a TCP/IP network is transmitted as raw data. Thus, any clever thief can read the information as it's being sent, create fake data requests, and forge responses.

2. Another equally vital consideration is the security of data on the client and server sites. Allowing external-site access to your server implies that people outside your site will have at least limited access to your file systems. Merely existing on a global network lets outsiders steal your data.

3. Finally, both user and provider must consider the problem of confirming that the other person is who he or she claims to be. Just as a server wants to confirm that persons ordering a service are who they claim to be, users need to confirm the sites to which they send sensitive information.

4. Three main techniques can secure server sites and data transmissions: firewalls, encrypted transmissions, and user/server authentication. When you install a firewall, you set up a single computer or a router to act as a filter that stands between all internal and external transmissions and allows only certain types of data to pass from one side to the other. An insecure site might allow almost anything to pass through; a more secure site can restrict transmissions to mail or nonanonymous FTP. Ports through a firewall can be either absolute (allowing everyone, or no one to go through) or user-secure (allowing only select users with password to go through).

5. Encrypted transmissions encode data transmissions. S-HTTP and SSL have been proposed as alternative methods of encoding transmitted data. S-HTTP provides encryption services to WWW browsers, while SSL provides security and encryption services to any application at the socket, or intercomputer communications, level. Two common encryption techniques are public-key and private-key encryption. Public-key encryption lets you broadcast an encoding key while maintaining a private decoding key. You can encrypt a message with public key; however, without knowing the private key, the recipient can't effectively decrypt the message.

6. With the private-key techniques, on the other hand, the sender and the receiver must share key information. A combination of public and private-key transmission is normally used to create secure channels. Public-key encryption is often used to sign and transmit private keys; the private keys are used for the bulk of the session to improve performances.

7. Authentication confirms the identity of a user or a server. At a simple level, this can be done with the use of passwords and user IDs. More complex schemes

allow you to store a digital signature that identifies the server site; the browser software must then request, compare, and verify the returned signature.

*Notes:*

S-HTTP (Security Hypertext Transfer Protocol)	протокол защищенной пересылки гипертекста;
SSL (Secure Sockets Layer)	протокол защищенных сокетов;
FTP (File Transfer Protocol)	протокол передачи файлов;
TCP/IP (Transmission Control Protocol/Internet Protocol)	протокол управления передачей/протокол IP (для объединения компьютерных сетей через Интернет)

*V. Read the first sentence of the text and mark pauses. Divide it into sense groups, find out the means of connection between these sense groups and between the words in each group.*

*VI. In paragraphs 2-,4 find English equivalents of the following words and word combinations.*

В равной степени; ограниченный доступ; подтверждение; закодированные передачи; определенный; незащищенный сайт; распознавание пользователя; выбирать пользователей; передача данных; фильтр.

*VII. Read paragraphs 5-6 and answer the questions.*

- 1 What is the difference between S-HTTP and SSL encode data transmissions?
- 2 What kind of key do you use to encrypt a message?
- 3 What do you use to create secure channels?
- 4 Without the private-key the recipient doesn't decrypt the message, does he?

*VIII. In paragraph 7 find information about the schemes of the identity of a user or a server.*

*IX. Say whether the following statements are true or false.*

- 1 The usage of credit-cards across the Internet is dangerously.
- 2 TCP/IP network is not well defended.
- 3 Users need to confirm the sites to which they send information.
- 4 There are five main techniques of data transmissions.
- 5 A secure site might allow almost anything to pass through.
- 6 The browser software must compare the signature.

*X. Complete the following sentences choosing the most suitable variant.*

- 1 Public-key encryption is used ....
  - a to transmit private-key
  - b to improve performance
  - c to create secure channels
- 2 S-HTTP provides....
  - a alternative methods of encoding transmitted data

- b encryption services to WWW browsers
  - c security and encryption services to any application at the socket
- 3 To install a firewall it is necessary ....
- a to set up one computer
  - b to set up two computers
  - c to set up four computers
- 4 Authentication means ....
- a the creation of secure channels
  - b the storage of a digital information
  - c the identity of a user
- 5 The ports in a firewall can be ....
- a absolute or user-secure
  - b public-key
  - c private-key

*XI. Make an outline of the text.*

*XII. Speak about the ways how to secure the information in the Internet.*

## **Part B**

*I. Define the meaning of the "x" words.*

exactly: exact = точно: x

certain: certainly = определенный: x

remarkable: remark = замечательный: x

condition: conditional = условие: x

satisfactory: satisfy = удовлетворительный: x

precede: precedence = предшествовать: x

occupation: occupy = занятие: x

*II. Complete the sentences with the given words:*

operating system	Assembler	skills
non-profit organization	beginner	income

- 1 Knowing special programs ... can create his own virus.
- 2 Programmer must be very clever and have some special ... .
- 3 Splendid knowledge of ... is very important.
- 4 ... unites programmers authors of viruses regardless of their qualification.
- 5 ... is preferred language to write viruses.
- 6 Creating viruses can bring constant ... to real professionals.

*III. Study the following word and choose:*

*a) nouns*

- |                |         |            |             |
|----------------|---------|------------|-------------|
| 1 employer     | employ  | employment | employed    |
| 2 powerful     | power   | powerless  |             |
| 3 professional | profess | profession | professedly |



*b) adjectives*

1	strategics	strategical	strategist
2	independent	independence	independency
3	operate	operating	operation

*c) adverbs*

1	speciality	specially	special	specialize
2	constant	constantly	constancy	
3	reason	Reasonably	reasonable	reasoning

*IV. Read the title and make your predictions about the contents of the text.*

### **WHO WRITES COMPUTER VIRUSES?**

In spite of the fact that a lot of people think, that to write a computer virus is a hardship, it is not exactly so. Using special programs called “Virus creators” even beginners in computer world can build their own viruses which will be a strain of certain major virus. The aim of creation of viruses is to become well known all over the world and to show the power.

Somehow the results of the attempt can be very sad, only real professionals can go famous and stay uncaught.

To write something really new and remarkable programmer should have some extra knowledge and skills, for example:

- good strategic thinking and intuition – releasing a virus and its descendants live their own independent life in nearly unpredictable conditions. Therefore the author must anticipate a lot of things;
- splendid knowledge of language of the Assembler and the operating systems he writes for – the more there are mistakes in the virus the quicker its will be caught;
- attention to details and a skill to solve the most varied tactical questions –one won’t write a compact, satisfactory working program without these abilities;
- a high professional discipline in order to join preceding points together.

A computer virus group is an informal non-profit organization, uniting programmers authors of viruses regardless of their qualifications. Everyone can become a member of the club, if he creates viruses, studies them for the reason of creation and spreading.

One can’t say that all of the group members write viruses in Assembler. Actually you don’t have to know any computer language or write any program code to become a member or a friend of the group. But programming in Assembler is preferred, Pascal, C++ and other high level languages are considered to be humiliating.

Sometimes, however, creating viruses can become a respectable occupation, bringing constant income. After all, no one but the author of the virus can bring valuable information on the way it should be treated and cured.

V. Say if the following statements are true or false.

- 1 To write computer virus is very easy for beginners .
- 2 The aim of creation of viruses is to stay uncaught .
- 3 It is not important to know computer languages.
- 4 Programmers authors of viruses must have high qualification.
- 5 Programmer can make mistakes in the virus and he will be never caught.
- 6 Creator of virus can use all high level computer languages, especially C++.
- 7 The author of the virus can bring useless information.

VI. Divide the text into logical parts and find the topical sentences in each part.

VII. Give a short summary of text B.

## Part C

I. Read the following text and entitle it.

1. Most Internet VR (virtual reality) projects don't support immersion (погружение), where you wear a helmet and gloves and are immersed in a simulated environment. But researchers at the Electronic Visualization Laboratory at the University of Illinois at Chicago have developed a new model for networked VR, called a Cave.

2. A Cave is a 3-D environment that consists of a 10- by 10- by 9-foot room with three rear-projection (заднее проектирование) screens for the walls and a down projection screens for the floor. Instead of wearing a helmet, viewers wear LCD stereo shutter glasses that separate the alternate fields going to the eyes. Images on the screen "move" with the viewers and surround them. An image's direction and positioning are determined by a person wearing a magnetic tracking device from Polhemus. The computers supplying the power behind a Cave are from the Silicon Graphics Supercomputing Systems Division. They can handle the billions of FLOPS required when interacting with complex representations of weather patterns, seismic activity or industrial CAD/CAM designs.

3. Tom DeFanti, the director of EVL, says that so far, researchers exploring networked Cave-to-Cave simulations have proven the concept of remote person-to-person immersive reality by performing basic actions (e.g. one person "touches" another person's head) over the Internet, using a T1 line.

4. A Cave represents the high end of networked VR. De Fanti notes that solutions like VRML (Virtual Reality Markup Language) can't address the needs of these high-end VR applications. If you need to sit in a simulation of a car, you want to reach out and see that everything is in right place and you can't do that in a workstation. The price of a Cave is high but several of clients are building Caves.

II. Read the text and answer the questions.

- 1 What model for networked VR was developed by researchers?
- 2 Where must rear-projection screens be situated?
- 3 How many FLOPS can computers handle?

- 4 What have Cave-to-Cave simulations proven?
- 5 What do viewers wear instead a helmet?
- 6 What is a Cave?

III. Find the place in paragraph 2 containing the information about the scheme of a new model for networked VR, called a Cave.

IV. Give the main points of the text in 5-6 sentences.

## UNIT 6

### Part A

### Word List



adapt	/əˈdæpt/	приспосабливать, адаптировать
detection	/dɪˈtekʃn/	определение, обнаружение
employ	/ɪmˈplɔɪ/	применять, использовать
entirely	/ɪnˈtaɪəli/	полностью
etch	/etʃ/	травитель; травление; травить
feedback	/ˈfiːdbæk/	обратная связь, обратное питание (эл.), реакция
impedance	/ɪmˈpiːdn̩s/	полное сопротивление, импеданс
inertia	/ɪˈnɜːʃə/	инерция
liquid-viscosity	/ˈlɪkwɪd vɪˈskɒsəti/	вязкость, коэффициент вязкости жидкости
manufacture	/ˌmænjʊˈfæktʃə(r)/	производить
micromachining	/ˈmaɪkrəʊməˈʃiːnɪŋ/	микрообработка
mixture	/ˈmɪkstʃə(r)/	смесь
operate	/ˈɒpəreɪt/	работать
processing	/prəˈsesɪŋ/	обработка
pure	/pjʊə(r)/	чистый
range	/reɪndʒ/	диапазон, пределы (измерений)
ratio	/ˈreɪʃiəʊ/	отношение, коэффициент
recognition	/ˌrekəɡˈnɪʃn/	распознавание
replace	/rɪˈpleɪs/	заменять
resolution	/ˌrezəˈluːʃn/	разрешающая способность, разрешение
selectivity	/səˌlekˈtɪvəti/	избирательность, разборчивость
sensitivity	/ˌsensəˈtɪvəti/	чувствительность
cross-sensitivity	/krɒsˌsənsəˈtɪvəti/	кросс-чувствительность
sensor	/ˈsensə(r)/	измерительный преобразователь, датчик; преобразователь; детектор, устройство считывания

*I. Study the following words and choose:*

*a) nouns*

- 1 replace, replaced, replaceable, replacement
- 2 process, processed, procession, processor
- 3 detect, detection, detector, detectable, detective
- 4 recognize, recognition, recognizable, recognizance
- 5 resolve, resolution, resolute, resolved

*b) adjectives*

- 1 computer, compute, computed, computational, computation
- 2 entity, entirely, entire, entirety
- 3 sense, sensitivity, sensor, sensitive, senseless, senselessness, sensible
- 4 vary, variety, various, varied
- 5 digit, digital, digitizer

*II. Arrange the words of the two groups in pairs with:*

*a) similar meaning*

- |                 |               |
|-----------------|---------------|
| 1 digital       | a choose      |
| 2 computational | b discovery   |
| 3 ratio         | c calculating |
| 4 replace       | d fully       |
| 5 entirely      | e numerical   |
| 6 processing    | f machining   |
| 7 operate       | g substitute  |
| 8 detection     | h work        |
| 9 select        | i correlation |

*b) contrary meaning*

- |             |                   |
|-------------|-------------------|
| 1 entirely  | a concealment     |
| 2 detection | b dirty           |
| 3 feedback  | c worsen          |
| 4 pure      | d partially       |
| 5 improve   | e separate        |
| 6 mix       | f homogeneous     |
| 7 various   | g disconnection   |
| 8 bond      | h direct coupling |

*III. Match the words with their definitions:*

- |              |   |
|--------------|---|
| 1 inertia    | a make suitable for a new use, need, situation  |
| 2 resolution | b extent; distance between limits   |
| 3 range      | c process of separating into constituents   |
| 4 employ     | d make use of   |
| 5 adapt      | e make practical use of (research, a discovery)   |
| 6 technique  | f method of doing smth expertly   |
| 7 apply      | g property of matter by which it remains in a state of rest or, if it is in motion, continues in the same direction and in a straight line unless it is acted upon by an external force |

*IV. Study the text and try to understand all details.*

## **ADVANCED SENSORS FOR MULTIFUNCTIONAL APPLICATIONS**

1. Thanks to the development of microprocessor electronics, digital systems can be found everywhere in industry from biomedical engineering to fashion computer design. New, computer-assisted technologies have given birth to interdisciplinary sciences such as computational biology, neural robotics, artificial intelligence and combinatorial drug production. With a very high signal-to-noise ratio and negligible error coefficient, digital systems have massively replaced old analog devices. Still, those systems do not have the information capacity of natural biologic sensors, which are entirely analog. Analog systems are capable of processing a large quantity of information at a much higher speed than the digital ones.

2. Biological sensors, operating at the complex nature-animal interface, process gigantic volumes of information in real time. Biological sensors have also a remarkable capability to operate as multifunctional devices. The sensors located in the tips of our fingers are not only touching receptors, they are pressure sensors, shape-memory devices, temperature sensors, and liquid-viscosity sensors as well. The human eye is not just a photographic camera but a complex system for image processing, color detection, light-intensity calibration, and motion detection. These sensors transform mechanical, thermal, and optical energies into electrical signals sent to the brain, which provides feedback information to the sensors through sophisticated pattern recognition procedures. Without the brain's feedback and pattern recognition capabilities, sensors alone would not be able to achieve high resolution, sensitivity, and selectivity.

3. Sensors rarely operate in a simple environment where only one parameter changes. Most physical and chemical sensors operate in complex environments where various parameters change simultaneously. The most critical problem is cross-sensitivity. A typical example is chemical sensors. Some electrochemical gas sensors have very high sensitivity in a pure gas environment but perform poorly in a gas mixture. Many multidisciplinary groups are attempting to develop advanced sensors with multifunction operations, similar to biological ones.

4. Advanced sensors for detecting simultaneously various parameters such as temperature, pressure, radiation, gas and vapor concentration, odor, acceleration, inertia, electric and magnetic fields, and more must provide not only high signal-to-noise ratio in a wide dynamic range but also good cross-sensitivity. In general, the sensors consist of two elements: a detector and a platform that communicates with the detector through an active interface with variable electrical, mechanical, optical, or chemical impedance. The platform must be able to generate output electrical signals carrying the information provided by the detector.

5. Because today's silicon micromachining technology is highly sophisticated, MEMS employing silicon offer many advantages in the design of multifunctional sensors. Silicon, an ideal electronic material and also a high-performance mechanical material, can be micromachined by using chemical and electrochemical etch

techniques. All classic technologies used in microelectronics manufacturing, including photolithography, diffusion, oxidation, ion implantation, and metal coating, can be applied in silicon micromachining.. A typical micromachining technique is based on SOI silicon wafers and wafer bonding. The process flow is based on wafer bonding of SOI wafers and can be used to manufacture various integrated resonant devices and systems for adaptive optics. MEMS technologies offer the potential for complimentary multifunctional devices by integrating various systems and principles.

*V. Say whether the following statements are true or false.*

- 1 Digital systems were changed by analog devices.
- 2 Natural biologic sensors possess the same information capacity as digital systems.
- 3 Biological sensors unable to process large volumes of information in real time.
- 4 Biological sensors can be named as multifunctional devices.
- 5 The problem of cross-sensitivity isn't considered to be acute nowadays.
- 6 There are three main parts of the sensors: a detector, a platform and environments.
- 7 Germanium is widely used in multifunctional micro-electromechanical sensor systems.

*VI. Read paragraph 1 of the text and answer the questions.*

- 1 Where are digital systems used nowadays?
- 2 Why have old analog systems been changed by digital systems?
- 3 What systems have the highest information capacity?

*VII. Read paragraph 2 and say what capabilities biological sensors have.*

*VIII. Look through paragraphs 2 and 3 and find English equivalents of the following words and word combinations: обрабатывают гигантские объёмы информации, замечательная способность, расположенные, также, сложный, обработка изображения, определение, мозг, сложные процедуры, распознавание, одновременно, чистая, пытаются, подобный.*

*IX. Read the first sentence of paragraph 4 and mark pauses. Divide it into sense groups, find out the means of connection between the words in each group.*

*X. Translate paragraphs 4 and 5 into Russian.*

*XI. Make an outline of the text.*

*XII. Speak about different kinds of sensors and their distinctive features.*

## **Part B**

*I. Define the meaning of the "x" word.*

approximation: approximately = приближение: x

density: dense = плотность: x

loss: lossless = потеря: x

frequency: frequent = частота: x

indicate: indicator = показывать: x

oscillate: oscillation = колебаться: х  
 modify: modification = модифицировать: х  
 dependence: depend = зависимость: х  
 determine: determination = определять: х

II. Find in the list the following parts of speech: a) nouns; b) adjectives; c) adverbs; d) verbs.

Resonator, mechanical, perturbation, electrical, originate, medium, occur; different, conductivity, chemical, performance, depend, various, frequently, external, lower, decrease, accuracy, measurement, substantially, generation.

III. Complete the sentences with the following words:

higher accuracy, to be based, to have been used, to be deposited, to be loaded, electrical perturbations, solid.

- 1 The most common sensor platform ..... on piezoelectric devices.
- 2 Different kinds of resonators .... in the design of multifunctional physical and chemical sensors.
- 3 Frequency may be measured with ... that any other parameter.
- 4 Thin-film coatings ... on the resonator.
- 5 If the resonator ... with a thin film, the boundary conditions will be modified.
- 6 ... can occur in metal films.
- 7 Various loading effects in liquid and ... media damp the oscillations of the resonator.

IV. Read the text and say which paragraph contains the information about the influence of different kinds of perturbations in solid and fluid media on the sensor performance.

### BULK AND SURFACE ACOUSTIC WAVE SENSORS

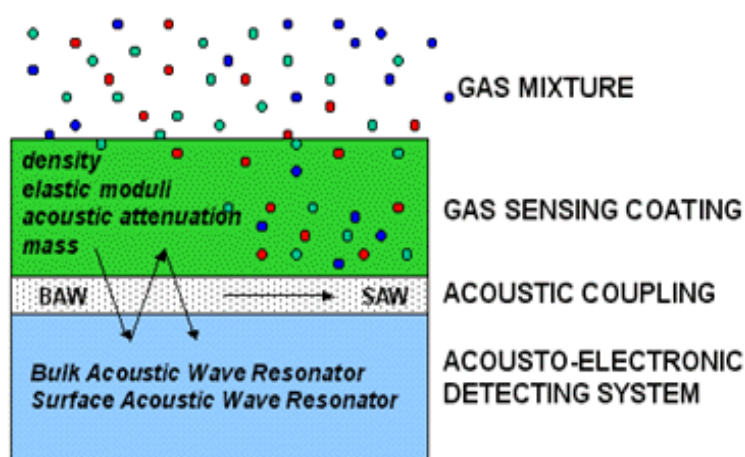

Figure 1

The most common sensor platform (платформа датчика) based on piezoelectric devices (пьезоэлектрические устройства). Figure 1 shows the basic structure of the acousto-electronic gas-sensing platform. Bulk and surface acoustic wave resonators have been used extensively in the design of multifunctional physical and chemical sensors, including

microbalances, viscosity sensors, humidity sensors, immuno-detectors, gas sensors, ion-intercalation monitors, and magnetic- and electric-field sensors.

Because frequency may be measured with higher accuracy than any other parameter, mechanical resonators are well suited for the design of high-sensitivity

sensors. Often, thin-film coatings sensitive to the measured parameter are deposited on the resonator because changes in the physical or chemical parameters of the film increase the resonance frequency shift. Resonator-based sensors measure resonance-frequency shifts caused by mechanical, chemical, or electrical perturbations of boundary conditions on the interface.

Mechanical boundary conditions provide continuity of particle velocity and stress on the interface boundary. A resonator without any load film in vacuum behaves like an unbounded, stress-free plate. If the resonator is loaded with a thin film, the boundary conditions will be modified. A dielectric film modifies mechanical boundary conditions, while a conducting film modifies both mechanical and electrical boundary conditions. A resonator coated with a film no longer has stress-free boundaries. Mechanical and electrical perturbations cause resonant-frequency shifts. With the assumptions of no internal electrical sources in quasistatic approximation where  $\vec{E} = -\nabla\Phi$  and  $\vec{\nabla} \cdot \vec{D} = \eta_o$ , where  $F$  is the electric potential, and  $h_o$  is the electrical charge density, lossless boundaries and only external perturbations the resonant frequency shift is given by:

$$\Delta f = \frac{i}{U} \int_s \left[ \underbrace{-\vec{\nabla}_1^* \cdot \vec{T}_2 - \vec{\nabla}_2 \cdot \vec{T}_1^*}_{\text{Mechanical Perturbations}} = \underbrace{\Phi_1^* (i\omega \vec{D}_2) + \Phi_2 (i\omega \vec{D}_1)}_{\text{Electrical Perturbations}} \right] \cdot \vec{n} dS$$

where  $U$  is the acoustic energy stored in the resonator mode,  $T$  is the stress tensor, and  $*$  indicates a complex conjugate. The boundary conditions at the interface are:

$$\vec{T}_1 \cdot \vec{n} = \vec{T}_2 \cdot \vec{n} \quad \text{and} \quad \vec{n} \times \vec{E}_1 = \vec{n} \times \vec{E}_2$$

$$\vec{\nabla}_1 = \vec{\nabla}_2 \quad \text{and} \quad \vec{n} \times \vec{H}_1 = \vec{n} \times \vec{H}_2$$

where  $H$  is the magnetic field related to the electric field through Maxwell equations.

The regime of oscillation of a piezoelectric resonator can be modified by mechanical or electrical perturbations originating from the surrounding medium. Electrical perturbations can occur in metal films with different conductivity values deposited on the resonator or if the resonator is immersed in ion-conducting electrolyte. The influence of mechanical, chemical, and electrical perturbations in solid and fluid media on the sensor performance depends on the interface between the quartz resonator and the surrounding medium. Various loading effects in liquid and solid media damp the oscillations of the resonator and modify the sensor resolution. The resolution of the sensor is determined by the resonance frequency shift response to external perturbations and the capability of the monitoring electronics to measure accurately this frequency shift.

*V. Say if the following statements are true or false.*

- 1 Resonant-frequency shifts occur due to mechanical and electrical perturbations.
- 2 Frequency can't be defined with higher accuracy than any other characteristics.
- 3 A resonator with a load film in vacuum is similar to a stress-free plate.
- 4 The boundary conditions will be changed provided the resonator is with a load thin film.
- 5 Mechanical boundary conditions are changed by a dielectric film.



VI. Choose the best answer: a, b or c to complete the sentences.

- 1 The most common sensor platform is based on ...
  - a chemical devices
  - b dielectric devices
  - c piezoelectric devices
- 2 Mechanical resonators are well suited for the design of ...
  - a low sensitivity sensors
  - b high sensitivity sensors
  - c medium sensitivity sensors
- 3 Changes in the physical or chemical parameters of the film
  - a decrease the resonance frequency shift
  - b increase the resonance frequency shift
  - c stabilize the resonance frequency shift
- 4 Mechanical boundary conditions provide continuity of particle...
  - a rapidness
  - b slowness
  - c changes

VII. Divide the text into logical parts and find the topical sentences in each part.

VIII. Give a short summary of the text.

### Part C

I. Read the following text and entitle it.

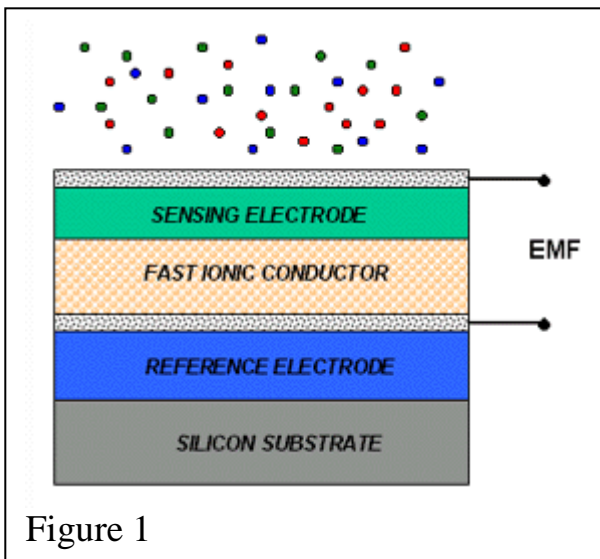

Figure 1

Another family of multifunctional sensor systems is electrochemical gas sensors (Figure 1), which use solid-state galvanic cells to monitor partial pressures of gases such as CO<sub>2</sub>, NO<sub>x</sub>, SO<sub>x</sub>, and hydrocarbons in gas mixtures. The sensor operates as a battery: the electromotive force (EMF) changes a function of chemical modifications of the cathode in the presence of the gas according to the following arrangement:

Pt electrode, gas | gas sensitive film ion conductor reference electrode | Pt electrode.

For example, to measure the EMF and the NO<sub>2</sub> partial pressure, a galvanic cell of the following type can be used:



The reaction in the cell is

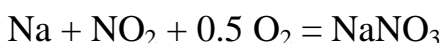

The relationship between the EMF and the NO<sub>2</sub> partial pressure is given by:

$$\text{EMF} \approx -\text{DG}[\text{NaNO}_3] + \text{DG}[\text{NO}_2] + kT \ln P[\text{NO}_2] + (kT/2) \ln P[\text{O}_2]$$

Where G is the Gibbs energy, P is the partial pressure, k is the Boltzmann's constant, and T is absolute temperature.

An electrochemical gas sensor for measuring partial pressure of CO<sub>2</sub> is fabricated using thin-film technology and silicon micromachining. The sensor operates at 350°C and the whole structure is built on top of micromachined silicon with platinum thin film heater. Thin Nasicon film is the ion-conducting separator. The sensing electrode is a mixture of barium and sodium carbonate deposited through reactive magnetron sputtering. The reference electrode is the isolation film of silicon nitride covering the platinum heating elements. The micromachined silicon substrate allows the heater to operate at 350°C while the surrounding area is at room temperature and the same silicon substrate could be used as a base of the controlling electronics.

The fabrication technology of the sensor allows integration of various gas sensors on the same substrate. Nasicon is used for all sensors as an ion-conducting separator of the battery. Only the sensing electrodes are different. For example, to detect NO<sub>x</sub> a sensing electrode of sodium nitride can be used.

*II. Answer the following questions on the contents of the text.*

- 1 What are solid-state galvanic cells used for?
- 2 What device operates as a battery?
- 3 At what temperature does an electrochemical gas sensor for measuring partial pressure of CO<sub>2</sub> operate?
- 4 What is built on top of micromachined silicon with platinum thin film heater?
- 5 What is thin Nasicon film?

*III. Read the text and say what makes it possible to integrate various gas sensors on the same substrate.*

*IV. List electrochemical sensors, their characteristics and use.*

*V. Give the main points of the text in 5-6 sentences.*

## UNIT 7

### Part A

### Word List

adapt	/ə'dæpt/	адаптировать
alphanumeric	/,ælfənju:'merɪk/	буквенно-цифровой
carrier	/'kæriə/	носитель
compatible	/kəm'pætəbl /	совместимый
enable	/ɪ'neɪbl/	позволять
evolution	/,i:və'lu:ʃn/	развитие
instantaneously	/,ɪnstən'teɪniəsli/	незамедлительно, тотчас
integrated	/'ɪntɪgreɪtɪd/	встроенный, интегрированный

obtain	/əb'teɪn/	получить
printed matter	/,prɪntɪd'mætə/	печатное издание, печатный материал
promote	/prə'məʊt/	продвигать, способствовать, учреждать
remote	/rɪ'məʊt/	отдаленный (удаленный)
still	/stɪl/	неподвижный, стационарный
successor	/sək'sesə/	преемник, наследник
technique	/tek'ni:k/	технология
traffic	/'træfɪk/	движение, трафик (объем данных, получаемых сервером (входящий трафик) или отправляемых сервером (исходящий трафик))
via	/vi:ə/, /'vaɪə/	через

*I. Study the following words and choose:*

*a) nouns*

- 1 evolve, evolutionary, evolution, evolutionary
- 2 integrated, integrate, integration, integrity
- 3 carry, carrier, carrying, carried
- 4 adapt, adapter, adapted, adapting, adaptability, adaptable

*b) adjectives*

- 1 instant, instantly, instantaneous, instantaneously
- 2 communicate, communication, communicative, communicator
- 3 interact, interactive, interaction, interactively
- 4 numeric, numerically, numerous, numeration

*II. Use the words in brackets in the appropriate forms to fit the spaces.*

- 1 Digital network is an ideal (carrier, carry, carried) of data communication.
- 2 This service enables subscribers to exchange (corresponding, correspondent, correspondence) on an automatic memory to memory basis.
- 3 It's a service (enable, enabling, enabled) a subscriber to obtain information over the public (switched, switch, switching) telecoms networks.
- 4 Larger networks of computers linked together become now (avail, available, availability).
- 5 Teleworking means working (remote, remotest, remotely) from an employer or normally expected place of work.
- 6 This system will use specially (adapting, adapted, adapt) word processors and electronic typewriters.

*III. Arrange the words of the two groups in pairs with :*

*a) similar meaning*

- |             |           |
|-------------|-----------|
| 1 evolution | a symbol  |
| 2 transmit  | b far     |
| 3 digit     | c through |

- |   |           |   |           |
|---|-----------|---|-----------|
| 4 | technique | d | advance   |
| 5 | remote    | e | picture   |
| 6 | via       | f | let       |
| 7 | enable    | g | carry     |
| 8 | image     | h | equipment |

b) *contrary meaning*

- |   |           |   |              |
|---|-----------|---|--------------|
| 1 | integrate | a | sender       |
| 2 | useful    | b | the same     |
| 3 | advanced  | c | exclude      |
| 4 | still     | d | impossible   |
| 5 | receiver  | e | disintegrate |
| 6 | various   | f | useless      |
| 7 | include   | g | obsolete     |
| 8 | possible  | h | moving       |

IV. *Match the words with their definitions.*

- |   |              |   |   |
|---|--------------|---|---|
| 1 | transmission | a | to get something by making an effort                                    |
| 2 | processing   | b | the movement of messages or signals                                     |
| 3 | obtain       | c | to encourage something to happen, increase or spread                    |
| 4 | successor    | d | sending out an electronic signal  |
| 5 | promote      | e | able to be used together  |
| 6 | traffic      | f | the thing you can get   |
| 7 | compatible   | g | a series of actions that computer performs on data to produce an output |
| 8 | available    | h | a person or thing that comes after smb/ smth                            |

V. *Study the text and try to understand all details.*

### COMPUTER COMMUNICATIONS

1. The present status of telecommunications is a result of a long evolution through more than a hundred years. It is interesting to note that the old telegraph system used digital transmission. When, many years later, telephony was introduced, analogue transmission was used. Telex, on the other hand, worked with a digital technique while video transmission in principle uses analogue transmission. Data communication is digital and a transition is now taking place where all services, voice, text, data and picture—will be integrated in a basic digital network. This digital network will be an ideal carrier of data communications and will promote the growth of such communications.

2. The development of data communications depends, to a great extent, on the development of data processing. So far, all the signs indicate a trend towards remote data processing which means a greater usage of data communications services.

3. A number of new text services have been, or will be, introduced shortly.

Firstly, a lot of interest has been shown in Teletex which is already being introduced in some countries. Teletex is an international service enabling subscribers to exchange correspondence on an automatic memory to memory basis, via telecommunications networks. As a successor to Telex, it will use specially adapted word processors and electronic typewriters and enable a 3-page A4 letter to be sent almost instantaneously from one end of the country to the other.

4. The Telefacsimile service is well established, though faster and more advanced systems (Group 4 types) will be introduced shortly. This service provides for the transmission and reproduction of still pictures and printed matter.

Videotex is a service enabling a subscriber to obtain information over the public switched telecoms network (PSTN) for presentation in alphanumeric and/or graphic form on a VDU (visual display unit) —usually a specially adapted TV receiver. This service is marketed under different names in different countries. Videotex subscribers may choose to have an additional service—electronic mailbox enabling them to send messages directly and instantaneously to one another. The UK viewdata system, which is an interactive service, should not be confused with Teletext, a one-way innovation service which TV companies broadcast.

5. Technically it will be possible to integrate various types of telecommunications networks (private and public, data and telephony) to form an Integrated Services Digital Network (цифровая сеть с комплексными услугами). ISDN is a wide band integrated services local communications system, offering the subscriber the complete spectrum of telecommunications services, including a new video telephone service as well as radio and TV broadcasts, all transmitted via optical fibre cables.

6. Despite this development towards ISDN, a number of specialized networks will have to live side by side for many years to come. From the customer's point of view, it is therefore essential that networks and services are compatible. It should be possible to use one and the same terminal for different devices and to send traffic over different networks. The question is how can this be realized? Could an integrated network be developed?

*VI. Say whether the following statements are true or false.*

- 1 The system of Telecommunications is not evolving nowadays.
- 2 The old telegraph transmitted messages in digital form.
- 3 Data communication is digital and shortly all services will be integrated in a basic digital network.
- 4 Teletex is a local service enabling subscribers to exchange messages via faxes.
- 5 Teletex will use adapted techniques but the service will be very slow.
- 6 Telefacsimile service is developing now. It provides instant transmission and reproduction only of images.
- 7 Videotex service enables a subscriber to obtain information by means of a specially adapted TV receiver.
- 8 A number of other techniques will develop as well as ISDN in the nearest future.

VII. Choose the best continuation for each of the following beginnings to match the contents of the text.

- 1 We are living in an age...
  - a of digital techniques
  - b of quickly changing and developing communication technologies
  - c of analogue information transmission
- 2 The development of data communication depends on the development of...
  - a the telegraph
  - b data processing
  - c telefaxes
- 3 Digital network will be an ideal carrier of...
  - a voice and images
  - b data communications
  - c additional services
- 4 Teletex is...
  - a an international service for exchange correspondence via telecommunications networks
  - b a local communications system
  - c a service providing data processing
- 5 The Telefacsimile service...
  - a makes an interactive service
  - b provides transmission and reproduction of still images and printed matter
  - c enables a 3-page A4 letter to be sent almost instantaneously
- 6 Videotex service...
  - a provides an electronic mailbox to a subscriber
  - b integrates various types of telecommunications
  - c includes a video telephone service
- 7 While developing ISDN, it's essential that...
  - a a customer has a terminal
  - b specialized networks will also develop
  - c networks and services are compatible

VIII. Choose the right English word or word combination in the box for the Russian fragments in brackets.

techniques	means	alphanumeric	to replace
integrated	data	instantaneously	printed
available	adapted	widespread	still
including	enables	numerous	transmit

- 1 Modern electronic systems (передают) information (незамедлительно) from a sender to a receiver.
- 2 The (широко распространенное) adoption of new communication (оборудование) has altered the communication process.

- 3 All services, voice, text and (данные) will be (объединены) in a digital network.
- 4 Computer communications use specially (приспособленные) word processors and electronic typewriters.
- 5 The telefax service (предоставляет возможность) to transmit and reproduce (неподвижные) pictures and (печатные) matter.
- 6 Videotex presents information in (буквенно-цифровой) or graphic form.
- 7 E-mail being very fast and convenient is beginning (заменять) slower paper media.
- 8 ISDN offers a subscriber (многочисленные) telecommunication services (включая) a new video telephone service.
- 9 Large-scale networks are becoming (доступный) as a (средства) of transmitting messages rapidly and worldwide.

IX. Look through the text again and answer the following questions.

- 1 What forms did telecommunications evolve into through more than a hundred years?
- 2 What will be an ideal carrier of data communications?
- 3 Teletex is an international service enabling to exchange correspondence via satellite service, isn't it?
- 4 Does teletex or telefacsimile service use adapted word processors and electric typewriters?
- 5 Why is electronic mail replacing paper media nowadays?
- 6 What is essential for all networks and services?

X. Use the diagram below and speak about possible development of integrated networks.

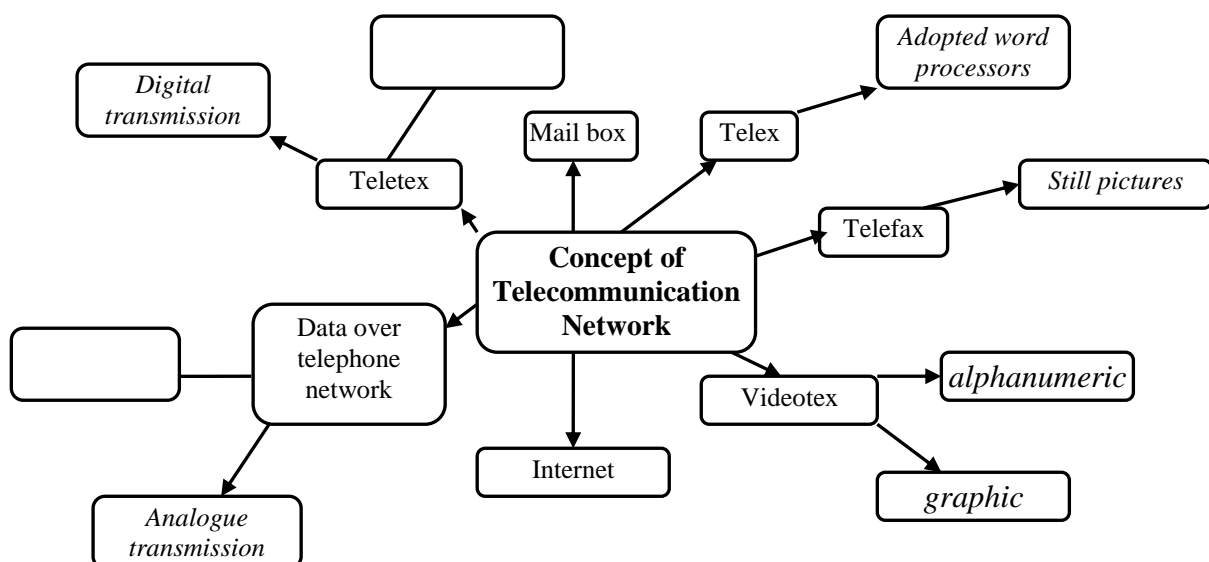

## Part B

I. Look through the English words and their Russian equivalents facilitating reading text B.

supervisory	/,sju:pə'vaizəri/	наблюдательный, контролирующий
maintain	/meɪn'teɪn/	поддерживать, сохранять
upload	/ʌpləʊd/	загрузка
downstream	/'daʊnstri:m/	смещение по ходу ленты
proprietary	/prə'praɪət(ə)rɪ/	собственный, патентованный
assign	/ə'saɪn/	определять, назначать
affordable	/ə'fɔ:dəbl/	возможный, допустимый
twisted pair	/'twɪstɪd'peə/	витая пара
splitter	/'splɪtə/	расщепитель, приемный распределитель
premises	/'premɪsɪz/	помещение, здание, дом
upgrade	/ʌp'greɪd/	улучшать
bandwidth	/,bænd'wɪðθ/	ширина полосы частот
download	/daʊn'ləʊd/	загрузка
shield	/,ʃi:ld/	экран, защита

II. Define the meaning of the "X" word:

supervise: supervisory = x: контролирующий

provide: provision = обеспечивать: x

maintain: maintenance = поддерживать: x

afford: affordable = x: допустимый

twist: twisted = x: переплетенный

connect: connector = x: соединитель

vary: variable = менять, разнообразить: x

require: requirement = требовать: x

install: installation = устанавливать: x

assign: assignment = предоставлять: x

III. Find in the list the following parts of speech:

a) nouns

1 exist, existence, existing, existed, existent

2 alternative, alternatively, alternator, alternation

3 frequent, frequency, frequently, frequentative

4 converse, conversable, conversation, conversational

b) adjectives

1 supervise, supervision, supervisory, supervised

2 cell, cellular, cellulite, cellulose

3 avail, available, availability, availably

4 digit, digitalization, digital, digitize

c) verbs



- 1 splitter, split, splitting, splitted
- 2 utility, utilize, utilized, utilization
- 3 additional, addition, add, additionally
- 4 significance, significant, signify, signification

*IV. Complete the sentences with the following words in the box. Translate completed sentences into Russian.*

require	independent	twisted-pair	installation
utilized	additional	equipment	channel
digital	upgrading	available	upload
copper	supervisory	affordable	

- 1 A common ISDN interface standard has a (цифровой) communications line consisting of three (независимый) channels.
- 2 The Data (канал) is used to carry signalling and (контролирующий) information to the network.
- 3 Satellite systems (требуют) the use of a modem to maintain the (загрузка).
- 4 Cable companies can also offer (допустимый) broadband services over (медный) coaxial or fibre networks.
- 5 DSL technology allows the full bandwidth of the copper (витая пара) telephone cabling to be (использованный).
- 6 This involves (дополнительный) hardware and (установка).
- 7 The telephone company's (оборудование) might need (улучшение).
- 8 DSL-based services can be made (допустимый) to the customer at extremely competitive prices.

*V. Read the text "Broadband communications" and say what communications services are available to customers.*

## **BROADBAND COMMUNICATIONS**

### **Integrated Services Digital Network (ISDN)**

ISDN services can be carried over existing telephone network infrastructure to terminal adapters (TAs) in the client machine. A common ISDN interface standard has a digital communications line consisting of three independent channels: two Bearer (B) channels, each at 64Kbit/s, and one Data (D) channel at 16Kbit/s. The D channel is used to carry signalling and supervisory information to the network, while the B channels carry the data and can be linked to provide a 128Kbits data channel.

### **Wireless connections**

The wireless alternatives come in two forms: satellite and cellular. Satellite systems require the use of a modem to maintain the upload. Downstream bandwidth is provided via a dedicated satellite dish, connector hardware and proprietary software.

Cellular systems use assigned radio frequencies and are based around a network of transmitters that are arranged in a cellular network, much like cellular mobile phone systems.

## The cable alternative

Cable companies can also offer affordable broadband services over copper coaxial or fibre infrastructure networks. The connection is shared by several customers on a branch, so actual connection rates are variable, unlike ISDN and DSL.

## Digital Subscriber Line (DSL)

DSL technology capitalises on the existing network of copper infrastructure, but allows digital signals to be carried rather than analogue. It allows the full bandwidth of the copper twisted-pair telephone cabling to be utilized.

With splitter-based services, the DSL signal is pulled out from the phone line as it enters your premises and is wired separately to a DSL modem. This involves additional hardware and installation by the service provider at the customer site. The shielded option involves no installation, but the telephone company's equipment and some of your equipment might need upgrading.

With Asymmetric Digital Subscriber Line (ADSL), most of the duplex bandwidth is devoted to the downstream direction, with only a small proportion of bandwidth being available for upstream. Much Internet traffic through the client's connection, such as Web browsing, downloads and video streaming, needs high downstream bandwidth, but user requests and responses are less significant and therefore require less on the upstream. In addition, a small proportion of the downstream bandwidth can be devoted to voice rather than data, allowing you to hold phone conversations without requiring a separate line. DSL-based services are a very low-cost option when compared to other solutions offering similar bandwidth, so they can be made available to the customer at extremely competitive prices.

### VI. Match the terms and their definitions.

- |   |                         |   |  |
|---|-------------------------|---|--|
| 1 | ISDN                    | a | DSL system that separates the digital signals from the analogue signals                  |
| 2 | TA                      | b | Digital channel used to carry ISDN signalling and supervisory information to the network |
| 3 | Data channel            | c | Device installed on a PC to allow it to receive ISDN signals                             |
| 4 | Bearer channel          | d | Integrated Services Digital Network  |
| 5 | DSL                     | e | Asymmetric Digital Subscriber Line   |
| 6 | Splitter-based services | f | Digital channel used to carry ISDN data  |
| 7 | ADSL                    | g | Digital Subscriber Line  |

### VII. Say whether the following statements are true or false.

- 1 ISDN can only operate over a special digital telephone line.
- 2 Computers connected to a satellite system do not need a modem.
- 3 Cellular networks work in a similar way to mobile phone systems.
- 4 DSL systems use analogue signals.

- 5 You need a separate line to hold normal phone conversations on an ADSL system.
- 6 DSL-based services are a very cheap option.

VIII. Choose the best answer to the following questions.

- 1 How many channels does an ISDN system usually use?
  - a one channel
  - b three independent channels
  - c two channels
- 2 What types of wireless systems are mentioned in the text?
  - a satellite and cellular systems
  - b air transceivers and hand-held radio transceivers
  - c mobile phone systems
- 3 What do PCs connected to a satellite system use to send data?
  - a copper coaxial cable
  - b optical fibre
  - c satellite dish, connector hardware and software
- 4 What types of cables are used in a cable network system?
  - a twisted-pair
  - b copper wires
  - c copper coaxial or fibre cable
- 5 Compared to the downstream bandwidth, the upstream bandwidth in an ADSL Line is:
  - a larger
  - b smaller
  - c the same
- 6 Which type of broadband service is the cheapest?
  - a ISDN
  - b wireless system
  - c DSL

IX. Give a short summary of the text presenting the advantages\disadvantages of the broadband communications systems mentioned in the text.

### Part C

1. Read the following text and entitle it. Use notes to facilitate reading it.

intend	/in'tend/	намереваться
US Department of Defense		Министерство обороны США
fee	/fi:/	налог, плата
set up		установленный
triangulation	/traɪ,æŋɡju'leɪʃ(ə)n/	тригонометрическая съемка
latitude	/'lætɪtju:d/	широта
longitude	/'lɒndʒɪtju:d/	долгота

altitude	/'æltɪ'tju:d/	высота над уровнем моря
bearing	/'beərɪŋ/	азимут
augmentation	/,ɔ:gmen'teɪfŋ/	увеличение частоты
accurate	/'ækjʊrɪt/	точный
beacon	/'bi:kən/	маяк, радиомаяк

II. Answer the following questions on the contents of the text.

- 1 What is GPS?
- 2 What are GPS functions?
- 3 Thanks to what is a today GPS extremely accurate?
- 4 Are there any factors affecting the accuracy of GPS receivers?
- 5 What devices can improve GPS accuracy?
- 6 How are GPS satellites powered?
- 7 There are some factors that degrade the GPS signal, aren't there?

III. Read the text and say how GPS works.

### WHAT IS GPS?

The Global Positioning System (GPS) is a satellite-based navigation system made up of a network of 24 satellites placed into orbit by the U.S. Department of Defense. GPS was originally intended for military applications, but in the 1980s, the government made the system available for civilian use. GPS works in any weather conditions, anywhere in the world, 24 hours a day. There are no subscription fees or setup charges to use GPS.

GPS satellites circle the earth twice a day in a very precise orbit and transmit signal information to earth. GPS receivers take this information and use triangulation to calculate the user's exact location. Essentially, the GPS receiver compares the time a signal was transmitted by a satellite with the time it was received. The time difference tells the GPS receiver how far away the satellite is. Now, with distance measurements from a few more satellites, the receiver can determine the user's position and display it on the unit's electronic map.

A GPS receiver must be locked on to the signal of at least three satellites to calculate a 2D position (latitude and longitude) and track movement. With four or more satellites in view, the receiver can determine the user's 3D position (latitude, longitude and altitude). Once the user's position has been determined, the GPS unit can calculate other information, such as speed, bearing (азимут), track, trip distance, distance to destination, sunrise and sunset time and more.

Today's GPS receivers are extremely accurate, thanks to their parallel multi-channel design. Garmin's 12 parallel channel receivers are quick to lock onto satellites when first turned on and they maintain strong locks, even in dense foliage or urban settings with tall buildings. Certain atmospheric factors and other sources of error can affect the accuracy of GPS receivers. Garmin GPS receivers are accurate to within 15 meters on average.

Newer Garmin GPS receivers with WAAS (Wide Area Augmentation System) capability can improve accuracy to less than three meters on average. No additional equipment or fees are required to take advantage of WAAS. Users can also get better accuracy with Differential GPS (DGPS), which corrects GPS signals within an average of three to five meters. This system consists of a network of towers that receive GPS signals and transmit a corrected signal by beacon transmitters. In order to get the corrected signal, users must have a differential beacon receiver and beacon antenna in addition to their GPS.

The 24 satellites that make up the GPS space segment are orbiting the earth about 12,000 miles above us. They are constantly moving, making two complete orbits in less than 24 hours. These satellites are travelling at speeds of roughly 7,000 miles an hour.

GPS satellites are powered by solar energy. They have backup batteries onboard to keep them running in the event of a solar eclipse, when there's no solar power. Small rocket boosters on each satellite keep them flying in the correct path.

Here are some other interesting facts about the GPS satellites:

- The first GPS satellite was launched in 1978.
- A full constellation of 24 satellites was achieved in 1994.
- Each satellite is built to last about 10 years. Replacements are constantly being built and launched into orbit.
- A GPS satellite weighs approximately 2,000 pounds and is about 17 feet across with the solar panels extended.
- Transmitter power is only 50 watts or less.

Factors that can degrade the GPS signal and thus affect accuracy include the following:

- **Ionosphere and troposphere delays** — The satellite signal slows as it passes through the atmosphere. The GPS system uses a built-in model that calculates an average amount of delay to partially correct for this type of error.
- **Signal multipath** — This occurs when the GPS signal is reflected off objects such as tall buildings or large rock surfaces before it reaches the receiver. This increases the travel time of the signal, thereby causing errors.
- **Receiver clock errors** — A receiver's built-in clock is not as accurate as the atomic clocks onboard the GPS satellites. Therefore, it may have very slight timing errors.
- **Orbital errors** — Also known as ephemeris errors, these are inaccuracies of the satellite's reported location.
- **Number of satellites visible** — The more satellites a GPS receiver can "see," the better the accuracy. Buildings, terrain, electronic interference, or sometimes even dense foliage can block signal reception, causing position errors or possibly no position reading at all. GPS units typically will not work indoors, underwater or underground.
- **Satellite geometry/shading** — This refers to the relative position of the satellites at any given time. Ideal satellite geometry exists when the satellites are located at

wide angles relative to each other. Poor geometry results when the satellites are located in a line or in a tight grouping.

- **Intentional degradation** of the satellite signal — Selective Availability (SA) is an intentional degradation of the signal once imposed by the U.S. Department of Defense.

IV. List the major factors that can degrade the GPS signals.

V. Give the main points of the text in 5-6 sentences.

## UNIT 8

### Part A

### Word List

abdomen	/'æbdəmən/	брюшная полость, живот
accurate	/'ækjərət/	точный, правильный, тщательный
attenuation	/ə'tenju'eɪʃn/	истощение, ослабление; затухание
emergent	/i'mɜ:dʒənt/	неожиданный, внезапный
essence	/'esns/	сущность, существо; существование
exploratory	/ɪk'splɒrətəri/	исследующий, исследовательский
exposure	/ɪk'spəʊʒə/	выставление; подвергание
inpatient	/'ɪnpeɪfnt/	стационарный больной
lesion	/'li:ʒn/	повреждение, поражение
manipulate	/mə'nɪpjuleɪt/	манипулировать, умело обращаться; воздействовать, влиять
outpatient	/'aʊtpeɪfnt/	амбулаторный больной
over-riding	/,əʊvə'raɪdɪŋ/	основной, первостепенный
reassure	/,ri:ə'ʃʊə/	заверять, убеждать, успокаивать
relevant	/'reləvənt/	уместный, относящийся к делу
respiration	/,respə'reɪʃn/	дыхание; вдох и выдох
search	/'sɜ:tʃ/	искать; исследовать; проникать
superimpose	/,su:pə'ɪm'pəʊz/	накладывать (одно на другое)
supine	/sju:'paɪn/	лежащий навзничь; инертный, вялый
suspend	/sə'spend/	вешать, подвешивать; приостанавливать, откладывать
tissue	/'tɪʃju:/ /'tɪʃu:/	ткань
undergo	/,ʌndə'gəʊ/	испытывать, переносить, подвергаться

I. Study the following words and choose:

a) nouns

- 1 respiration, respiratory, respire, respirator, respite
- 2 expose, exposure, expositive, exposition, expository
- 3 reading, read, readability, readable, reader

- 4 diagnostic, diagnosis, diagnostician, diagnostics
- 5 exploratory, explore, explorer, exploration

*b) adjectives*

- 1 decide, decisive, decision, decidedly
- 2 measurement, measurable, measurer, measureless, measure
- 3 therapeutic, therapeutics, therapist, therapy
- 4 investigate, investigative, investigator, investigatory
- 5 emerge, emergent, emergency

*II. Match the words with their definitions.*

- |               |   |   |
|---------------|---|---|
| 1 surgery     | a | to put smth over smth else so that both can be seen |
| 2 attenuate   | b | for treating or curing disease                      |
| 3 reprocess   | c | to become thin, weak, less valuable                 |
| 4 superimpose | d | directly connected with the subject                 |
| 5 supine      | e | performing of medical operations                    |
| 6 therapeutic | f | to make known for the first time                    |
| 7 relevant    | g | being on one's back, looking upwards                |
| 8 introduce   | h | to treat smth so that it can be used again          |
| 9 abdomen     | i | someone staying in a hospital for treatment         |
| 10 inpatient  | j | part of the body between the chest and legs         |

*III. Arrange the words of the two groups in pairs with:*

*a) similar meaning*

- |                 |   |                    |
|-----------------|---|--------------------|
| 1 respiration   | a | influence, effect  |
| 2 impact        | b | illness            |
| 3 undergo       | c | connected          |
| 4 scan          | d | breathing          |
| 5 disease       | e | work               |
| 6 conventional  | f | examine closely    |
| 7 manipulate    | g | accepted           |
| 8 relevant      | h | experience         |
| 9 investigation | i | study, examination |
| 10 overriding   | j | prevailing         |

*b) contrary meaning*

- |                 |   |                 |
|-----------------|---|-----------------|
| 1 inpatient     | a | irrelevant      |
| 2 process       | b | approximate     |
| 3 relevant      | c | intensification |
| 4 overriding    | d | slow, gradual   |
| 5 accurate      | e | reprocess       |
| 6 attenuation   | f | health          |
| 7 disease       | g | unconventional  |
| 8 emergent      | h | carry out       |
| 9 undergo       | i | outpatient      |
| 10 conventional | j | unimportant     |

*IV. Study the text and try to understand the details.*

## **COMPUTED TOMOGRAPHY**

1. In the two decades since computed tomography (CT) was introduced by Sir Godfrey Hounsfield it has become established as a powerful diagnostic tool and one that is relevant to many branches of surgery. Used appropriately, CT is capable of making a major impact on management decisions.

2. The essence of the CT technology is that the scanner rotates an X-ray tube around the patient in an arc and the emergent radiation beam is measured by photoelectric detectors. A computer is used to display the measurements of the patient, based on the density of tissues to X-rays. The image can be thought of as a cross-sectional radiograph but unlike radiography there is no superimposition of structures and the detector/computer system makes the technique very sensitive.

3. From the patient's point of view CT examination is simple. In the majority of examinations all the patient has to do is lie on the couch while the machine makes the readings. Examination is usually carried out with the patient supine, although specialized indications may require specific positions. Exposures typically last a few seconds, and suspended respiration is required when the chest or abdomen are being examined; a diagnostic examination may not be possible if the patient has difficulty holding their breath, as respiratory movement may cause artifact. Other areas can be studied during quiet respiration.

4. The CT section is a cross-sectional radiograph in which tissues are displayed on a grey scale according to their attenuation value. Dense structures such as cortical bone appear light, whereas low density areas like air appear dark, as in the case with conventional radiographs. The attenuation of tissues on CT is displayed on a wider scale than can be shown effectively on one image, however. The display console therefore allows the image to be manipulated so that areas at different points on the attenuation scale can be examined. The basic image data can also be manipulated in other ways. Measurements from a small area can be reprocessed to give a high resolution image, this is useful for demonstrating small structures. Information may also be reformatted in different planes, on three-dimensional perspective views, to provide a more anatomical display.

5. The principal advantage of CT is that it provides a clear, accurate display of tissues without superimposition of structures. Disease processes may be detected at an earlier stage than is possible with other techniques, and lesions may be detected in areas which are difficult to assess with conventional imaging. The technique is not limited to specific organs: since all of the tissues in a body section are displayed it can be used to search for disease sites.

6. Although CT is effective in disease detection and localization, characterization of lesions is more difficult, since many have similar attenuation characteristics. The other main disadvantages of CT are high capital cost of the equipment and the fact that it employs ionizing radiation. CT is therefore used with care around radiosensitive structures such as the eye, or in children and young people, and only for over-riding indications in pregnant women.



7. Although the capital and running costs of CT are high, the technique is undoubtedly cost effective. It can be used to achieve an early diagnosis in patients who would otherwise need to undergo a large number of alternative investigations, and it can be performed on an outpatient basis, reducing costs for inpatient investigation. Moreover, the diagnostic and therapeutic applications of CT frequently replace exploratory laparotomy, or other major surgical procedures.

8. In the future the clinical role of CT will need to be reassessed as MRI develops. For the present, CT is the mainstay of cross-sectional imaging.

*V. In paragraphs 2 and 3 find English equivalents of the following words and word combinations:* сущность технологии, рентгеновская трубка, возникающий радиационный луч, плотность тканей, радиограф с поперечным сечением, лежать на кушетке, пациент в положении лежа, специальные указания, приостановленное дыхание, грудная клетка, брюшная полость.

*VI. In paragraph 2 find the information about the essence of examination.*

*VII. Look through paragraph 3 and say how the procedure is performed.*

*VIII. Read paragraphs 5 and 6 and answer the questions.*

- 1 What is the main advantage of CT?
- 2 When can diseases and lesions be detected?
- 3 Why is the technique not limited to specific organs?
- 4 Are there any disadvantages of CT?
- 5 CT should be used with care around radiosensitive structures, shouldn't it?
- 6 Can CT be applied to pregnant women and little children?

*IX. Read paragraph 7 and explain why the technology of CT is undoubtedly cost effective.*

*X. Say whether the following statements are true or false.*

- 1 CT is a powerful diagnostic tool and is relevant to many branches of surgery.
- 2 There is superimposition of structures in the obtained structures.
- 3 CT examination is simple.
- 4 All body areas can be studied during quiet respiration.
- 5 A high resolution image is useful for demonstrating small structures.
- 6 The technique is limited to specific organs.
- 7 CT often replaces many other surgical procedures.

*XI. Complete the following sentences choosing the most suitable variant.*

- 1 The essence of the CT technology is that...
  - a detectors record the emission of energy
  - b strong magnetic field is utilized
  - c the scanner rotates an X-ray tube around the patient
- 2 In the majority of examinations the patient should...

- a lie on the couch supine
  - b stand straight
  - c breath deeply
- 3 The principal advantage of CT is that...
- a tissues are displayed on a grey scale
  - b it provides a clear accurate display without superimposition of structures
  - c exposures last a few seconds
- 4 Lesions and disease processes can be detected...
- a at an earlier stage
  - b when the disease cannot be cured
  - c when exploratory laparotomy is needed
- 5 The technique is cost effective because...
- a its capital and running cost are high
  - b it is used to demonstrate small structures
  - c it allows to achieve an early diagnosis

*XII. Speak about CT as a powerful diagnostic tool.*

## **Part B**

*I. Define the meaning of the "x" word.*

administer: administration= назначать: x

detect: detection= обнаруживать: x

order: disorder= порядок: x

alter: alteration= изменять: x

local: localize= местный: x

cancer: cancerous= рак: x

short-lived: long-lived= кратковременный: x

seize: seizure= хватать: x

*II. Find in the list the following parts of speech: a) nouns, b) adjectives, c) adverbs, d) verbs.*

Emission, physiologic, emit, evaluate, responsive, surgery, scanner, multiple, permit, attach, commonly, appropriate, brightness, accumulate, restriction, plenty, exposure, affect, enhance.

*III. Complete the sentences with the following words: are not responsive, are displayed, exposure, detection, radioactive, radiologist, colors, brightness, alterations.*

- 1 PET images are based on the ... of radiation from the emission of positrons.
- 2 PET scans detect diseases and disorders that ... to medical therapy.
- 3 Images ... on the monitor of a computer.
- 4 Cyclotron is a machine producing a ... substance.
- 5 Different levels of tissue or organ function are represented by different ... or degrees of ... .

- 6 A specialist who has got a specialized training in nuclear medicine is called a ...
- 7 PET helps physicians to detect ... in biochemical processes.
- 8 During the procedure of PET imaging patient's radiation ... is low.

#### IV. Read the text and entitle it.

Positron emission tomography, also called PET imaging or PET scan, is a diagnostic examination that involves the acquisition of physiologic images based on the detection of radiation from the emission of positrons. Positrons are tiny particles emitted from a radioactive substance administered to the patient. The subsequent images of the human body developed with this technique are used to evaluate a variety of diseases.

PET scans are used most often to detect cancer and to examine the effects of cancer therapy, heart diseases, brain tumors or seizure disorders that are not responsive to medical therapy and are therefore candidates for surgery.



The PET scanner has a hole in the middle and looks like a large doughnut. Within this machine are multiple rings of detectors that record the emission of energy from the radioactive substance in your body and permit an image of your body to be obtained. While lying on a cushioned examination table, you will be moved into the hole of the machine. The images are

displayed on the monitor of a nearby computer, which is similar in appearance to the personal computer you may have at home.

Before the examination begins, a radioactive substance is produced in the machine called a cyclotron and attached, or tagged, to a natural body compound, most commonly glucose, but sometimes water or ammonia. Once this substance is administered to the patient, the radioactivity localizes in appropriate areas of the body and is detected by the PET scanner. Different colors or degrees of brightness on a PET image represent different levels of tissue or organ function. For example, because healthy tissue uses glucose for energy, it accumulates some of the tagged glucose, which will show up on the PET images. However, cancerous tissue, which uses more glucose than normal tissue, will accumulate more of a substance and appear brighter than normal tissue on the PET images.

The procedure may take 30 to 45 minutes. It must be done by a radiologist who has specialized in nuclear medicine and has substantial experience with PET. A radiologist who has specialized training in PET will interpret the images and forward a report to your referring physician. Usually, there are no restrictions on daily routine after the test, although you should drink plenty of

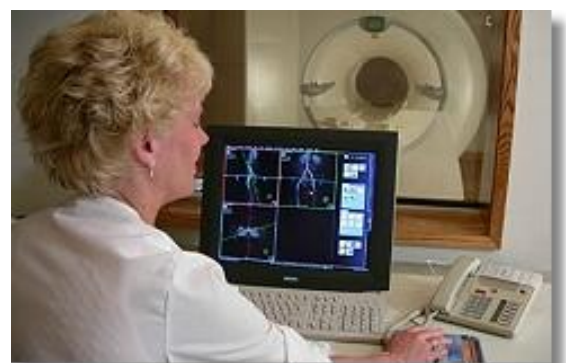

fluids to flush the radioactive substance from your body. Because PET allows study of body function, it can help physicians detect alterations in biochemical processes that suggest disease before changes in anatomy are apparent with other imaging tests, such as CT or MRI. Because radioactivity is short-lived, your radiation exposure is low. The substance amount is so small that it does not affect the normal processes of the body.

Finally, the value of a PET scan is enhanced when it is a part of a larger diagnostic work-up. This often entails comparison of the PET scan with other imaging studies, such as CT or MRI.

V. Read the text and say which paragraph contains the information about some common uses of the procedure.

VI. Say whether the following statements are true or false.

- 1 PET imaging is based on the detection of radiation from emission of electrons.
- 2 PET scans are used to evaluate only heart disorders.
- 3 During the examination a patient is moved into the hole of the machine.
- 4 Similar colors on a PET image represent different levels of tissue.
- 5 The procedure must be done by a physician.
- 6 PET scan is usually a part of a larger diagnostic work.

VII. Match parts of the sentences.

- |  |   |
|--|---|
| 1 Positrons are tiny particles                 | a to the patient.                       |
| 2 Within the PET scanner there are             | b radioactivity is short-lived.         |
| 3 Radioactive substance is administered        | c emitted from a radioactive substance. |
| 4 There are no restrictions on a daily routine | d after the test.                       |
| 5 Your radiation exposure is low, because      | e multiple rings of detectors.          |

VIII. Give a short summary of text B.

## Part C

I. Read the text and define its main idea.

### MAGNETIC RESONANCE IMAGING (MRI)

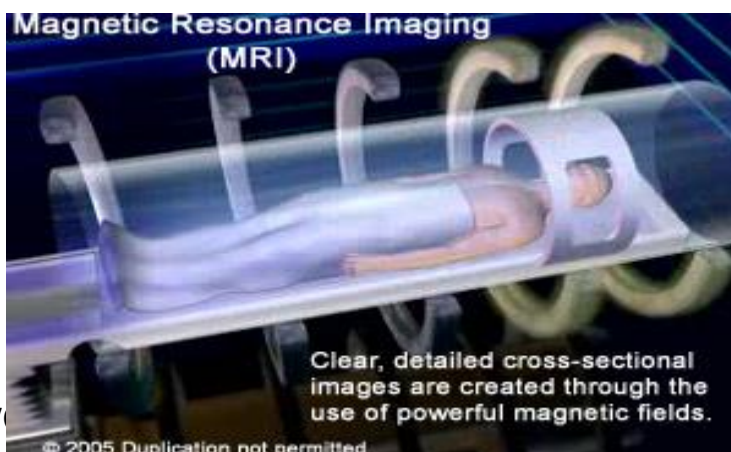

Magnetic resonance imaging (MRI) also called magnetic resonance tomography (MRT) is a method of creating images of the inside of opaque organs in living organisms as well as detecting the amount of bound water in geological

structures. It is primarily used to demonstrate pathological or other physiological alterations of living tissues and is a commonly used form of medical imaging. MRI has also found many novel applications outside of the medical and biological fields such as rock permeability to hydrocarbons and certain non-destructive testing methods such as produce and timber quality characterization.

MRI was developed from knowledge gained in the study of nuclear magnetic resonance. The original name for the medical technology is nuclear magnetic resonance imaging (NMRI), but the word nuclear is almost universally dropped. This is done to avoid the negative connotations of the word nuclear, and to prevent patients from associating the examination with radiation exposure, which is not one of the safety concerns for MRI. Scientists still use an NMR when discussing non-medical devices operating on the same principles. Unfortunately the devices themselves are very expensive with several hundred thousands dollars per year upkeep costs.

In clinical practice MRI is used to distinguish pathological tissue (such as brain tumor) from normal tissue. One of the advantages of an MRI scan is that, according to current medical knowledge, it is harmless to the patient. It utilizes strong magnetic fields and non-ionizing radiation in the radio frequency range. Compare it to CT scans and traditional X-rays which involve doses of ionizing radiation and may increase the chance of malignancy, especially in children receiving multiple examinations.

The typical MRI examination consists of 5-20 sequences, each of which are chosen to provide a particular type of information about the subject tissues. This information is then synthesized by the interpreting physician. The presence of a ferromagnetic foreign body in the subject, or a metallic implant (like surgical prostheses, or pacemakers) can present a (relative or absolute) contraindication towards MRI scanning: interaction of the magnetic and radiofrequency fields with such an object can lead to: trauma due to the shifting of the object in the magnetic field, thermal injury from radiofrequency induction of heating of the object, or failure of an implanted device.

Because of MRI's superior imaging of soft tissues, it is now being utilized to specifically locate tumors within the body in preparation for radiation therapy treatments. For therapy simulation, a patient is placed in specific, reproducible, body position and scanned. The MRI system then computes the precise location, shape and orientation of tumor mass, correcting for any spatial distortion inherent in the system. The patient is then marked or tattooed with points which, when combined with the specific body position, will permit precise triangulation for radiation therapy.

## *II. Read the text and answer the questions.*

- 1 What is MRI?
- 2 Why is the word "nuclear" almost universally dropped from the name of this medical technology?
- 3 What are common uses of MRI in clinical practice?
- 4 How is the procedure performed?

5 Are there any limitations of MRI?

*III. Using information from the text name advantages of the MRI procedure.*

*IV. Read the text and describe a typical MRI examination.*

*V. Give the main points of the text in 5-6 sentences.*

